

U.S. Army Vehicle Guide

504

Series Module

TWILIGHT: 2000™



Game Designers' Workshop

Wes
© 85

U.S. Army Vehicle Guide

What does the remote turret on an M1A2 look like? When the Sergeant York air defense gun was withdrawn from production, what happened to the vehicles already built and what replaced it? What were the organization and equipment levels of an armored division? A light infantry division? What was the basis of issue of the LAV-75?

The *U.S. Army Vehicle Guide* is designed to answer these and many other questions raised by *Twilight: 2000* players. It also serves as a comprehensive future projection of current armored vehicle design trends. For both game players and AFV buffs, the *Vehicle Guide* is a gold mine of information. It includes:

- Eight pages of color plates; thirty-six full color vehicles in all.
- Complete game statistics for all combat vehicles in U.S. service in the year 2000.
- A global U.S. order of battle as of the summer of the year 2000. Every division and separate brigade; its manpower and combat vehicle strengths, and its current loyalties.
- Pre-war tables of organization and equipment, showing which vehicles were assigned to which units and in what quantities.
- Hints on modeling vehicles for use in miniatures games.

Design & Development: Frank Chadwick, Loren K. Wiseman

Art Director: Paul R. Banner

Associate Art Director: Barbie Pratt

Cover, Interior Illustrations, and Color Plates: Steve Venters



Twilight: 2000™

Series Module

Game Designers' Workshop

P.O. Box 1646, Bloomington, Illinois 61702-1646

Copyright© 1986, Game Designers' Workshop, Inc. All rights reserved. No part of this game may be reproduced in any form or by any means without permission in writing from the publisher. Printed in the U.S.A.

ISBN 0-943580-54-4

U.S. Army Vehicle Guide

Contents

The U.S. Army.....	2
Order of Battle.....	2
United States Military Government.....	2
ForceCom.....	2
CentCom.....	2
NorthAG.....	3
CentAG.....	3
United States Civilian Government.....	3
DefCom.....	3
Unit History and Current Status.....	3
Armored Divisions.....	3
Infantry Divisions.....	4
Marine Divisions.....	11
Separate Brigades.....	12
Armored Cavalry Regiments.....	15
Organization.....	17
Introduction.....	17
Authorized Levels of Principal	
Combat Vehicles & Weapons.....	17
Tank Battalion.....	17
Mechanized Battalion.....	17
Light Infantry Battalion.....	18
Light Attack Battalion.....	18
Light Motorized Battalion.....	18
Light Tank/Assault Gun Battalion.....	18
Field Artillery Battalion.....	18
Field Artillery Rocket Battery.....	18
Attack Helicopter Battalion.....	18
Air Cavalry Squadron.....	18
Armored Cavalry Squadron.....	18
Divisional Cavalry Squadron.....	18
ADA Battalion.....	19
Marine Infantry Battalion.....	19
Marine Recon Battalion.....	19
Marine Amphibious Tractor Battalion.....	19
Marine LAV-25 Battalion.....	19
Marine Antiarmor Company.....	19
Components of Divisions and Selected	
non-Divisional Units.....	19
Vehicle Descriptions.....	29
Unarmored Cargo Vehicles.....	29
Armored Personnel Carriers.....	29
Light Combat Vehicles.....	30
Engineer Vehicles.....	31
Main Battle Tanks.....	31
Self-Propelled Artillery.....	31
Towed Guns.....	33
Firearms.....	33
Rockets.....	33
Antiarmor Missiles.....	33
Antiaircraft Missiles.....	33
Large Caliber Guns.....	33
Howitzers.....	34
Ammunition.....	34
Additions to the Fire Charts.....	35

Rocket Launchers.....	35
Antiarmor Missiles.....	35
Antiaircraft Missiles.....	35
Large Caliber Guns.....	35
Howitzers.....	35
Additions to the Vehicle Damage Location Lists.....	36
Unarmored Cargo.....	36
Armored Personnel Carriers.....	36
Light Combat Vehicles.....	36
Engineer Vehicles.....	36
Main Battle Tanks.....	36
Self-Propelled Artillery.....	36
The Color Plate Notes.....	38
The Color Plates.....	21
Vehicle Modeling Tips.....	46

Credits

Design and Development: Frank Chadwick & Loren Wiseman
Art Direction: Rich Banner
Associate Art Director: Barbie Pratt
Cover, Interior Illustrations and Color Plates: Steve Venters

Game Designers' Workshop
PO Box 1646
Bloomington, IL 61702-1646

Copyright © 1986 by Game Designers' Workshop. All Rights Reserved. ISBN 0-943580-54-4 *Twilight: 2000* is Game Designers' Workshop's trademark for its role-playing game of survival in a devastated world.



The U.S. Army

This chapter provides an overview of the current (as of July 1, 2000) location and approximate strengths of major military units of the United States Army and Marine Corps. First, it contains an order of battle giving command structures, locations, and subordinate units. This is followed by a brief history and current status rundown of each of the major units listed, as of July 1, 2000. Referees have considerable latitude to alter this data based on the events of their campaign after that date.

Strengths of units are given in overall manpower to the nearest thousand and current tank (or assault gun) strength. Most of these units have additional numbers of lighter armored vehicles and soft-skinned tactical vehicles. They have also acquired non-issue vehicles by various means.

Order of Battle

I. UNITED STATES MILITARY GOVERNMENT

ForceCom

Strategic Reserve

Current Location: Colorado

100th Infantry Division

Cadet Brigade

Current Location: Hawaii

29th Infantry Brigade

1st US ARMY

Current Location: United States East Coast

XII US Corps

78th Infantry Division

43rd Military Police Brigade

5th US ARMY

Current Location: Central & South Central United States

194th Armored Brigade

197th Infantry Brigade (Mechanized)

90 US Corps

49th Armored Division

95th Infantry Division

122 US Corps

85th Infantry Division (1st Brigade only)

98th Infantry Division

6th US ARMY

Current Location: California

63 US Corps

40th Infantry Division (Mechanized) (less 1st Brigade)

46th Infantry Division

221st Military Police Brigade

89th US Corps

91st Infantry Division (Light)

49th Military Police Brigade

9th US ARMY

Current Location: US and Canadian Pacific Northwest

X US Corps

10th Infantry Division (Mountain)

1st Infantry Brigade (Arctic Recon)

2nd Infantry Brigade (Arctic Recon)

VIII US Corps

47th Infantry Division

104th Infantry Division (Light)

CentCom

3rd US ARMY

Current Location: Iran

75th Infantry Regiment (Ranger)

I US Amphib Corps

1st Marine Division

3rd Marine Division

24th Infantry Division (Mechanized)

XVIII US Airborne Corps

9th Infantry Division (Motorized)

82nd Airborne Division

101st Air Assault Division

6th Air Cavalry Combat Brigade

8th US Army*Current Location:* Korea**II US Amphib Corps**

4th Marine Division (23rd Regiment only)

5th Marine Division

6th Marine Division (16th Regiment only)

II US Corps

7th Infantry Division (Light) (1st Brigade only)

26th Infantry Division (Light)

45th Infantry Division

VI US Corps

2nd Infantry Division

25th Infantry Division (Light)

41st Infantry Division

163rd Armored Cavalry Regiment

NorthAG**XI US Corps***Current Location:* Northern Poland (subordinate to Third German Army)

2nd Marine Division

5th Infantry Division (Mechanized)

8th Infantry Division (Mechanized)

50th Armored Division

116th Armored Cavalry Regiment

7th US Army*Current Location:* Central Germany**I US Corps**

3rd Infantry Division (Mechanized)

6th Infantry Division (Light)

38th Infantry Division

278th Armored Cavalry Regiment

V US Corps

3rd Armored Division

4th Infantry Division (Mechanized)

28th Infantry Division

11th Armored Cavalry Regiment

VII US Corps

1st Infantry Division (Mechanized)

36th Infantry Division

2nd Armored Cavalry Regiment

CentAG**III US Corps***Current Location:* Southern Germany (subordinate to First German Army)

1st Cavalry Division

2nd Armored Division (2nd Brigade only)

44th Armored Division

3rd Armored Cavalry Regiment

4th US ARMY*Current Location:* Austria**XV US Corps**

1st Armored Division

43rd Infantry Division

70th Infantry Division (Light)

XXIII US Corps

35th Infantry Division (Mechanized)

40th Infantry Division (Mechanized) (1st Brigade only)

107th Armored Cavalry Regiment

II. UNITED STATES CIVILIAN GOVERNMENT**DefCom****III Military Region***Current Location:* Southeastern United States

108th Infantry Division

30th Engineer Brigade (Combat)

184th Infantry Brigade

228th Infantry Brigade

V Military Region*Current Location:* United States Northern Plains

84th Infantry Division (Light)

35th Engineer Brigade

Combined Operations Headquarters, South*Current Location:* Jugoslavia**IV US Corps**

42nd Infantry Division

76th Infantry Division (Light)

80th Infantry Division (Light)

Unit History and Current Status**Armored Divisions****1ST ARMORED DIVISION**

A pre-war regular army division stationed at Ansbach, Germany under command of the VII US Corps. The division crossed the inter-German border on 12/5/96 and was involved in combat against Soviet forces on 12/6/96. In September of 1997 the division was withdrawn from the front in Poland and rushed to the south of Germany where it came under command of XV US Corps and went into action against Czech and Italian forces driving into Bavaria.

Subordination: XV US Corps*Current Location:* Austria*Manpower:* 4000*Tanks:* 8 M1

12 M1A1

16 M1A2

1ST CAVALRY DIVISION

A pre-war regular army division, configured as a two-brigade armored division, and stationed at Fort Hood, Texas, under command of the III US Corps. The division was placed on alert in October of 1996, at which time it was brought up to strength by the addition of 155th Armored Brigade (Mississippi National Guard). The division was transferred by air to Europe in November of 1996. All heavy equipment was left at Fort Hood and the division took over equipment stored at POMCUS sites in the eastern Netherlands. Upon arrival in Europe, the division came under command of I Netherlands Corps, but reverted to control of III US Corps on 11/30/96 when that headquarters became operational in Germany. The division moved into the Federal Republic of Germany on 12/1/96, crossed the inter-German border on 12/10/96, and was involved in combat against Soviet forces on 12/15/96.

Subordination: III US Corps*Current Location:* Southern Germany*Manpower:* 3000*Tanks:* 10 M1

18 M1A1
20 M1A2

2ND ARMORED DIVISION (2nd Brigade)

A pre-war regular army division stationed at Fort Hood, Texas, under command of the III US Corps. The division's 3rd Brigade was deployed forward at Garlstedt, Germany, under direct control of 7th US Army. On 10/21/96 the main body of the division was placed on alert and began to transfer by air to Germany in mid-November of that year. The division left its heavy equipment at Fort Hood and took over equipment stored at POMCUS sites in northern Germany. Upon formation in Germany, the division remained under direct command of 7th US Army until 11/30/96 when it came under command of III US Corps. The division crossed the inter-German border on 12/3/96 and was engaged in combat against Soviet forces on 12/7/96. During the retreat from Warsaw in September of 1997 the division suffered heavy casualties from tactical nuclear strikes and upon arrival in Germany was withdrawn from the front to regroup. The division was reformed as a single brigade (the 2nd) and excess command and support troops were used as replacements for other units in Germany.

Subordination: III US Corps

Current Location: Southern Germany

Manpower: 300

Tanks: 1 M1
3 M1A1
1 M1A2

3RD ARMORED DIVISION

A pre-war regular division deployed at Frankfurt, Germany under command of the V US Corps. The division crossed the inter-German border on 12/5/96 and was first engaged against Soviet forces on 12/11/96. The 3rd Armored Division participated in every major offensive undertaken by U.S. forces in the central European theater .

Subordination: V US Corps

Current Location: central Germany

Manpower: 5000

Tanks: 30 M1
2 M1A1
13 M1A2
9 LAV-75

44th ARMORED DIVISION

The Division headquarters was formed on 2/30/97 at Fort Hood, Texas and took command of 30th Armored (Tennessee NG), 31st Armored (Alabama NG) and 218th Mechanized (South Carolina NG) Brigades, all of which were at that time in federal service. The division was declared fully operational on 4/25/97 and in May began deploying by air and sea to Europe. Upon arrival in Germany the division came under command of III US Corps and participated in the summer offensive into Poland. In September of that year, the division retreated in good order with the main body of the corps into Germany, where it has remained ever since.

Subordination: III US Corps

Current Location: Southern Germany

Manpower: 3000

Tanks: 12 M60A4
2 M1
4 M1A1

49TH ARMORED DIVISION

A National Guard division consisting of the 1st, 2nd and 3rd Brigades (all Texas NG). The division was brought into federal service on 11/1/96 and moved to Chicago, Illinois in early 1997 in preparation for transit to Europe. Due to a shipping shortage and concerns as to the safety of shipping in the north Atlantic, the division remained in the Chicago area throughout the spring and summer. In late 1997, the division was deployed in a disaster relief and emergency security role in the northern Illinois and Indiana area, but soon was moved out of the Chicago metropolitan area. The division's 1st Brigade moved to Fort McCoy, Wisconsin, the 2nd Brigade to Camp Atterbury, Indiana, and the 3rd Brigade and division headquarters to Springfield, Illinois.

With the outbreak of hostilities with Mexico in mid-1998, the division moved south by road and river barge to Fort Sill, Oklahoma and came under command of the newly formed 90th Corps. By autumn, the division was involved in sporadic and confused combat on a broad front against elements of the Mexican army, marauder bands, and numerous para-military organizations. In 1999, the division was used to spearhead the US 5th Army's drive to clear Texas of hostile armed bands and suffered heavy vehicle losses in central Texas when the division was counterattacked by the Soviet "Division Cuba." By late 1999, the division had withdrawn to southern Oklahoma where the front was stabilized.

Subordination: 90 US Corps

Current Location: Oklahoma

Manpower: 3000

Tanks: 4 M60A4
8 M1
1 M1A1
7 Stingrays
3 LAV-75

50TH ARMORED DIVISION

A National Guard division consisting of the 1st (New Jersey NG), 2nd (New Jersey NG) and 86th (Vermont NG) Brigades. The division was alerted on 8/21/96 and brought into federal service on 11/1/96. The division was deployed to Europe by sea and air in May of 1997 and upon arrival came under command of VII US Corps. In October of that year the division was shifted north and came under command of XI US Corps.

Subordination: XI US Corps

Current Location: Northern Poland

Manpower: 2000

Tanks: 5 M60A4
16 M1
12 M1A1

Infantry Divisions

1ST INFANTRY DIVISION (Mechanized)

A pre-war regular army division stationed at Göppingen, Germany under the command of VII Corps. The division crossed the inter-German border on 12/4/96 and was engaged in combat against Soviet forces on 12/8/96. The division participated in every major campaign in Poland and eastern Germany of the war.

Subordination: VII US Corps

Current Location: Central Germany



Manpower: 5000
Tanks: 10 M1
 16 M1A1
 4 M1A2

2ND INFANTRY DIVISION

A pre-war regular army division stationed in Korea at Tongduchon-Ni under the command of US 8th Army. The division was first engaged against North Korean commando units on 12/19/96 and by 1/3/97 was actively engaged against mechanized elements of the North Korean Army. The division participated in holding actions along the 38th Parallel throughout the first half of 1997 and in summer moved north as part of 8th Army's offensive toward the Yalu. On 8/1/97 forward elements of the division relieved the surrounded air head of the 2nd Chinese Parachute Division. When Soviet counterattacks cut the division's line of communication, it briefly came under command of the Chinese 28th Army. Upon destruction of the headquarters detachment of 28th Chinese Army by a tactical nuclear strike, and the subsequent disintegration of the forces of that army, the 2nd Infantry Division conducted a two week overland march through enemy held territory and reestablished contact with the main body of VI US Corps.

Subordination: VI US Corps
Current Location: Korea
Manpower: 2000
Tanks: 4 M1

3RD INFANTRY DIVISION (Mechanized)

A pre-war regular army division stationed in Germany at Würzburg under the command of V US Corps. The division crossed the inter-German border on 12/3/96 and on 12/7/96 entered combat against Soviet troops. In June of 1997 the division was transferred to I US Corps.

Subordination: I US Corps
Current Location: central Germany
Manpower: 5,000
Tanks: 10 M1A1

4TH INFANTRY DIVISION (Mechanized)

A pre-war regular division stationed at Fort Carson, Colorado,

under command of the III US Corps. The division was alerted in early October of 1996 and on 10/21/96 began to deploy by air to Germany. All heavy equipment was left at Fort Carson and the division took over equipment stored at POMCUS sites in western Germany. Upon formation in Germany the division came under command of V US Corps. On 12/7/96 the division crossed the inter-German border and by 12/11/96 was involved in combat with Soviet forces.

Subordination: V US Corps
Current Location: central Germany
Manpower: 1000
Tanks: 8 M1
 10 M1A1

5TH INFANTRY DIVISION (Mechanized)

A pre-war regular army division with two active brigades stationed at Fort Polk, Louisiana and under command of the III US Corps. The division was put on alert in October of 1996 and brought up to strength by the addition of the 256th Mechanized Brigade (Louisiana National Guard). The division was deployed to Germany by air and sea in December of 1996 and upon arrival entered combat still under III US Corps. In April of 1997 the division was transferred to 3rd German Army where it came under command of Panzergruppe Oberdorf. The division fought through southern Poland and participated in the Battle of Czystochowa (May 24th to June 17th). In early August the division withdrew from Czystochowa under orders from the German commander of the Panzergruppe and retired to Germany. In October the division was shifted north and came under command of XI US Corps, recently activated in-theater. In the summer of 2000, the division spearheaded the corps' drive into northern Poland.

Subordination: XI US Corps
Current Location: Poland
Manpower: 3000
Tanks: 9 M1
 21 M1A1
 12 M1A2

6TH INFANTRY DIVISION (Light)

A pre-war regular division stationed at Fort Richardson, Alaska. The division was placed on alert in October of 1995 and brought up to strength with a National Guard roundout brigade. The division was deployed to Norway by air in November of 1996 and by December was in combat against Soviet troops in northern Norway. By the spring of 1997, the division was on the banks of the Litsa River but suffering heavy casualties and unable to advance further. Following the failure of the June offensive and the stabilization of the northern front, the 6th Division was transferred by sea to northern Germany and on 8/7/97 came under command of I Corps.

Subordination: I US Corps
Current Location: Central Germany
Manpower: 2000
Tanks: 6 LAV-75

7TH INFANTRY DIVISION (Light) (1st Brigade)

A pre-war regular army light division stationed at Fort Ord, California. The 7th division was placed on alert status in October of 1996 and in January of 1997 was deployed by air to Korea. Upon arrival in Korea, the division came under the command of II US Corps and was soon actively engaged against

mechanized elements of the North Korean Army. The division participated in holding actions along the 38th Parallel throughout the first half of 1997 and in summer moved north as part of 8th Army's offensive toward the Yalu. Following the collapse of the northern Chinese front, the division was surrounded by Soviet and North Korean armored forces and was nearly annihilated.

Subordination: II US Corps

Current Location: Korea

Manpower: 500

Tanks: 0

8TH INFANTRY DIVISION (Mechanized)

A pre-war regular army division stationed in Bad Kreuznach, Germany under command of V US Corps. The division crossed the inter-German border on 12/5/96 and was first engaged in combat against Soviet forces on 12/10/96. The division suffered heavy casualties in the retreat from Warsaw in the fall of 1997 and was withdrawn from the front lines to be reformed. In January of 1998, the division re-entered the lines in support of XI U.S. Corps. In the summer of 2000, the division was detached from the corps and made its way overland through northern Poland to Latvia. Its present location and status are unknown.

Subordination: XI US Corps

Current Location: Latvia

Manpower: 1000

Tanks: 2 M1

7 M1A1

2 LAV-75

9 Stingrays

9TH INFANTRY DIVISION (Motorized)

A pre-war regular infantry division, the only formation of the U.S. Army organized as a light motorized division. The division deployed by air to Saudi Arabia in March of 1997 and in May moved to Bushehr, Iran in support of the 101st Air Assault Division's airhead. By summer the division was heavily engaged against Soviet air assault and mechanized units in central Iran in the vicinity of Esfahan. The division fought numerous delaying actions in the retreat south to the northern shore of the Persian Gulf and assisted the 101st Division in the defense of Bushehr. In November and December the division carried out numerous attacks against retreating Soviet rearguards and in 1998 participated in the clearing operations in the Bushehr-Shiras-Bandar 'Abbas triangle. Since then the division has been used in a variety of deep penetration raids.

Subordination: XVIII US Airborne Corps

Current Location: Iran

Manpower: 1500

Tanks: 12 LAV-75

10TH INFANTRY DIVISION (Mountain)

A pre-war regular division stationed at Fort Drum, New York. The division was placed on alert in early October of 1996 and on 11/1/96 began to deploy to Norway by air. The division entered combat against Soviet troops in the Bardufoss area in mid-November and in a series of costly holding engagements blunted the Soviet drive toward Narvik, gaining time for additional Norwegian and NATO reserves to deploy in the north. In March of 1997 the survivors of the division were withdrawn from the front lines to regroup and absorb replacements. In Ju-

ly the division deployed by air to Fort Greely, Alaska, where it joined the 1st and 2nd Infantry Brigades (Arctic Recon) (Alaska National Guard) to form the X US Corps. Throughout summer and fall the division fought a series of successful holding actions in the vicinity of Forts Wainwright and Greely against Soviet arctic mechanized forces. In 1998 the division spearheaded X Corps' counteroffensive. By March, the division had captured Fairbanks and in early April elements of the division, in conjunction with 2nd Infantry Brigade (Arctic Recon) (Alaska National Guard) had isolated Anchorage, severing the most important Soviet logistical links to forces further south. As both sides' logistical situations deteriorated, combat wound down to a series of local actions aimed mostly at securing the limited food growing areas.

Subordination: X US Corps

Current Location: Pacific Northwest

Manpower: 1000

Tanks: 2 LAV-75

24TH INFANTRY DIVISION (Mechanized)

A pre-war regular army division organized on a two-brigade basis and stationed at Fort Stewart, Georgia. The division was placed on alert in early October of 1996 and brought up to strength by the 48th Mechanized Brigade (Georgia National Guard). The division began deploying by sea and air to Saudi Arabia in March of 1997. Forward elements of the division moved to Iran in May and were soon involved in combat with Soviet Air Assault units and Iranian Tudeh guerrillas in the vicinity of Bandar Khomeyni and Ahvuz. The division captured Ahvuz on 7/27/97, but retired under heavy enemy pressure six days later. The division carried out a successful defense of Bandar Khomeyni in the early fall and, following the airdrop of 82nd Division on Tabriz and subsequent severing of Soviet supply lines, carried out a successful drive north to Ahvuz. On 1/1/98, the division linked up with the retreating 82nd Division and conducted a staged withdrawal to the Bandar Khomeyni area. In December of 1999 the division was relieved of the defense of Bandar Khomeyni by 82nd Airborne Division and moved to Saudi Arabia to rest and refit. In July of 2000 the division moved to Chah Bahar and came under command of I US Amphibious Corps.

Subordination: I US Amphibious Corps

Current Location: Iran

Manpower: 2000

Tanks: 9 M1A2

25TH INFANTRY DIVISION (Light)

A pre-war regular army division stationed at Schofield Barracks, Hawaii. The division was alerted in October of 1996 and in January of 1997 deployed by air to Seoul, South Korea. Upon arrival, the division came under the command of VI US Corps and participated in a series of holding actions along the 38th parallel throughout the first half of 1997. The division participated in 8th Army's summer offensive toward the Yalu River and on 9/7/97, linked up with elements of the Chinese 31st Army. On 10/21/97, the division suffered six attacks by tactical nuclear weapons and received heavy casualties. While retiring toward Korea under heavy enemy pressure the division was overrun and disintegrated. In March of 1998 the division reformed in Korea with fewer than 1000 surviving personnel.

Subordination: VI US Corps

Current Location: Korea

Manpower: 600

Tanks: 0

26TH INFANTRY DIVISION (Light)

A National Guard division consisting of the 1st (Massachusetts NG), 2nd (Massachusetts NG) and 43rd (Connecticut NG) Brigades. The division came into federal service on 11/5/96 and deployed by air to Seoul, South Korea in February of 1997. Upon arrival it came under command of US II Corps and participated in holding actions along the 38th parallel throughout the first half of 1997. The division participated in 8th Army's summer offensive and in August was withdrawn into reserve behind II Corps. The division fought a series of successful rearguard actions during the autumn withdrawals and successfully returned to defensive positions with the main body of II Corps.

Subordination: II US Corps

Current Location: Korea

Manpower: 5000

Tanks: 3 LAV-75

28TH INFANTRY DIVISION

A National Guard division consisting of the 2nd, 55th and 56th Brigades, all Pennsylvania National Guard. The division came into federal service on 11/1/96. It deployed to Germany by sea and air in April of 1997 and upon arrival came under command of V Corps. The division participated in the offensive through Poland in 1997, but suffered heavy casualties from enemy conventional and nuclear attack in the withdrawal to Germany. In March of 1998, the division was withdrawn from the lines to reorganize and refit, but returned to combat in May of that year and has been in sporadic contact with hostile forces since then.

Subordination: V US Corps

Current Location: Central Germany

Manpower: 1000

Tanks: 4 M60A4

35TH INFANTRY DIVISION (Mechanized)

A National Guard division consisting of 67th Mechanized (Nebraska NG), 69th Mechanized (Kansas NG) and 149th Armored (Kentucky NG) Brigades. The division came into federal service on 8/23/96. The division began deploying to Germany by air and sea in November of 1996. Upon arrival in Germany it came under command of III US Corps and was engaged in combat in northern Germany by early December. In the spring of 1997, it came under command of XXIII US Corps.

Subordination: XXIII US Corps

Current Location: Austria

Manpower: 2000

Tanks: 14 M1

9 M1A1

36TH INFANTRY DIVISION (Mechanized)

The division headquarters was formed 3/17/97 at Fort Bragg, North Carolina and on 3/19/97 took under command 30th Mechanized (North Carolina NG), 32nd Mechanized (Wisconsin NG), and 81st Mechanized (Washington NG) Brigades, all of which were at that time in federal service. The division became operational on 5/2/97 and in mid-May began to deploy by sea and air to Europe. Upon arrival in Europe it came under command of V US Corps, but in June of 1997 was transferred to VII US Corps as replacement for 3rd Infantry Division



(Mechanized) which had been assigned to I US Corps. The division first entered combat on 6/3/97 and participated in the drive through Poland to the Soviet frontier. Following the initiation of nuclear warfare, the division withdrew in good order with the main body of the corps to Germany.

Subordination: VII US Corps

Current Location: Germany

Manpower: 5000

Tanks: 21 M60A4

10 M1

4 LAV-75

38TH INFANTRY DIVISION

A National Guard Division consisting of the 2nd (Indiana NG), 46th (Michigan NG) and 76th (Indiana NG) Brigades. The division came into federal service on 11/1/96. It deployed to Germany by sea and air in February and March of 1997, suffering some losses en route to Soviet commerce raiders. Upon arrival in Germany the division came under command of I Corps and went into a reserve position, but by late March was committed to combat in the drive toward the Polish border. The division was later withdrawn to central Germany in advance of the main body of the corps to organized defensive positions south of Berlin. In 1998 the division spearheaded the drive south into northern Czechoslovakia, later moving back into Germany through the Hof Gap.

Subordination: I US Corps

Current Location: Central Germany

Manpower: 4000

Tanks: 6 M60A4

40TH INFANTRY DIVISION (Mechanized) (1st Brigade)

A National Guard division consisting of 1st, 2nd and 3rd Brigades, all California National Guard. The division was brought into federal service on 11/1/96 and deployed to Europe by sea in May of 1997, along with the headquarters of the XXIII US Corps. Upon arrival in Germany the division came under command of the XXIII US Corps and in May entered the front lines in Poland. In August the division suffered heavy casualties from tactical nuclear weapons strikes and was withdrawn to Germany to reform. The survivors of the division were used to reform the

division's 1st brigade and excess command and support personnel were returned to the United States to form the cadre for an additional division.

Subordination: XXIII US Corps

Current Location: Austria

Manpower: 400

Tanks: 4 M60A4

2 M1

40TH INFANTRY DIVISION (Mechanized) (less 1st Brigade)

The division was formed at Camp Rilea, Oregon on 1/17/98 as the 40th Training Division from surviving command and support personnel of the 40th Infantry Division (Mechanized) which had been evacuated from Germany. The division was quickly brought up to strength by recent inductees and assigned a variety of security, disaster relief and reconstruction tasks in Oregon and northern California. In March the division came under command of the newly-activated 63rd US Corps and moved south by road. In May the division arrived at Camp Roberts, California. After being reinforced by a variety of armored vehicles the division was again redesignated as 40th Infantry Division (Mechanized) and committed to combat against elements of the Mexican Army and assorted armed bands.

Subordination: 63rd US Corps

Current Location: California

Manpower: 3000

Tanks: 8 M728 CEV

6 M60A4

2 Stingrays

2 LAV-75

4 M1

1 M1A1

1 M1A2

41ST INFANTRY DIVISION

Division headquarters was formed at Camp Atterbury, Indiana on 1/28/97 and took command of 33rd (Illinois National Guard), 73rd (Ohio National Guard) and 106th (Indiana National Guard) Infantry Brigades, all of which were at that time in federal service. The division was operational by 3/1/97 and began deploying to Korea by sea. Upon arrival in Korea, the division came under command of the VI US Corps and participated in holding actions along the 38th Parallel throughout the first half of 1997. In the summer the division moved north as part of 8th Army's offensive toward the Yalu. Upon disintegration of the northern Chinese armies, the division withdrew to central Korea along with the main body of the 8th Army.

Subordination: VI US Corps

Current Location: Korea

Manpower: 2000

Tanks: 0

42ND INFANTRY DIVISION

A National Guard division consisting of the 1st, 2nd and 27th Brigades (all New York National Guard). The division was brought into federal service on 11/1/96. The division remained in the United States through 1998 and was employed in a variety of internal security and civic action roles following the nuclear exchanges of 1997-98. In the autumn of 1999, the division was deployed by sea to Yugoslavia. Upon arrival it came under command of US IV Corps, the headquarters of which arrived in the same convoy as the division's 2nd Brigade. The division entered



combat against Croatian Nationalist Army units on 10/7/98.

Subordination: IV US Corps

Current Location: Yugoslavia

Manpower: 3000

Tanks: 6 M60A4

43RD INFANTRY DIVISION

Division headquarters was formed at Fort Devens, Massachusetts on 1/12/97 and took command of 187th Infantry, 205th Infantry and 157th Mechanized Brigades (all U.S. Army Reserve). The division was operational on 3/1/97 and began deploying to Europe by sea, suffering heavy casualties in transit from Soviet commerce raiders. Upon arrival in Germany the division came under direct command of 7th Army and spent the next six weeks reforming and absorbing replacements. On 6/19/97 the division came under command of VII Corps and participated in the offensive through Poland. In September of 1997 the division was withdrawn from the front in Poland and rushed to the south of Germany where it came under command of XV US Corps and went into action against Czech and Italian forces driving into Bavaria.

Subordination: XV US Corps

Current Location: Austria

Manpower: 1000

Tanks: 10 M60A4

45TH INFANTRY DIVISION

The division headquarters was formed on 1/13/97 at Fort Chaffee, Arkansas and took command of the 39th (Arkansas NG), 45th (Oklahoma NG), and 53rd (Florida NG) Infantry Brigades, all of which were in federal service at that time. The division became operational on 4/2/97 and began deploying to Korea by sea. Upon arrival in Korea, the division came under command of VI US Corps and participated in holding actions along the 38th Parallel throughout the first half of 1997. In the summer, the division moved north as part of 8th Army's offensive toward the Yalu. Upon disintegration of the northern Chinese armies, the division bore the brunt of numerous Soviet and North Korean counterattacks and became separated from the main body of VI Corps. Abandoning its heavy equipment, personnel of the division successfully broke out of the encircle-

ment and rejoined elements of the US II Corps, to which it was then subordinated.

Subordination: II US Corps

Current Location: Korea

Manpower: 2000

Tanks: 0

46TH INFANTRY DIVISION

The division headquarters was formed on 3/17/97 at Camp Blanding, Florida and took command of the 58th (Maryland NG), 92nd (Puerto Rican NG), and 116th (Virginia NG) Infantry Brigades. The division was operational on 6/1/97 and moved to Virginia in preparation for deployment to the European Theater. A shipping shortage delayed deployment of the division until mid-July. At that time deployment was further delayed due to the use of tactical nuclear weapons in the European Theater. In November the division was deployed on a variety of security and disaster relief missions along the eastern seaboard. In the spring of 1998 the division moved by road to Texas and was dispersed throughout the eastern part of the state on anti-riot duties. The outbreak of hostilities with Mexico caught the division badly spread out and major elements of the command were quickly overrun. The division suffered further losses from desertion and was not able to reform as a division until the fall of 1998. At that time the remnants of the division were regrouped at Fort Carson, Colorado and reinforced by local militia units brought into federal service. In October the division moved by road to central California and came under command of the 63rd US Corps.

Subordination: 63rd US Corps

Current Location: California

Manpower: 1000

Tanks: 0

47TH INFANTRY DIVISION

A National Guard Division consisting of the 1st (Minnesota NG), 34th (Iowa NG), and 66th (Illinois NG) Brigades. The division came into federal service on 11/1/96 and began deploying by air and sea to Fort Richardson, Alaska where it relieved the 6th Infantry Division (Light) of internal security duties. In July of 1997 outposts of the division were attacked by Soviet Spetsnaz units and shortly thereafter by elements of two arctic mechanized brigades. The division was pushed southeast in heavy fighting and retreated across the Canadian border where it was reinforced by elements of the Canadian Army. The appearance of additional Soviet troops, coupled with limited tactical nuclear strikes, inflicted heavy casualties on the division and by mid-1998 it had fallen back to northern Washington. The deteriorating logistical situation of the Soviet forces coupled with attacks on their rear areas by the US X Corps from the Fort Wainwright (east-central Alaska) and the arrival of the 104th Infantry Division halted the Soviet attack. At that time the division reverted to a defensive role and became responsible for internal security in the Washington-Oregon region.

Subordination: VIII US Corps

Current Location: Pacific Northwest

Manpower: 5000

Tanks: 0

70TH INFANTRY DIVISION (Light)

The division was formed at Livonia, Michigan on 7/20/98 by redesignation of the 70th Training Division (U.S. Army Reserve).

The division was declared fully operational on 8/1/98 and began moving by road to Virginia. In October of 1998 the division deployed by sea to Europe and upon arrival came under command of XV US Corps in southern Germany.

Subordination: XV US Corps

Current Location: Austria

Manpower: 2000

Tanks: 0

76TH INFANTRY DIVISION (Light)

The division was formed at West Hartford, Connecticut on 7/20/98 by redesignation of the 76th Training Division (U.S. Army Reserve). On 8/2/98, the division began moving overland to Virginia and suffered considerable casualties en route from bandit ambushes. The division arrived on the eastern seaboard in early October and began deploying to Yugoslavia by sea in late October. Upon arrival it came under command of US IV Corps and first entered combat on 11/5/98 against units of the Albanian Peoples Liberation Front.

Subordination: IV US Corps

Current Location: Yugoslavia

Manpower: 1000

Tanks: 0

78TH INFANTRY DIVISION (Light)

The division was formed at Edison, New Jersey on 7/20/98 by redesignation of the 78th Training Division (U.S. Army Reserve). Upon formation, the division was made responsible for disaster relief and internal security in the greater New York metropolitan region. The division immediately came into conflict with numerous armed bands and suffered steady losses from combat casualties and desertion. On 11/28/98 the division attempted an evacuation by water of its main body from Manhattan Island. The evacuation turned into a rout. The division lost over half of its remaining personnel and the remainder abandoned their equipment and dispersed into the countryside. In March of 1999 about 1000 survivors of the division were assembled at Fort Dix, New Jersey, and reorganized. The division has since remained at Fort Dix, undertaking light security missions in southern New Jersey.

Subordination: XII US Corps

Current Location: United States East Coast

Manpower: 1000

Tanks: 0

80TH INFANTRY DIVISION (Light)

The division was formed on 7/20/98 by redesignation of the 80th Training Division (U.S. Army Reserve) in Richmond, Virginia. In October of 1998 the division was deployed by sea to Yugoslavia where it came under command of the US IV Corps and entered combat against Croatian Nationalist Army units on 11/1/98.

Subordination: IV US Corps

Current Location: Yugoslavia

Manpower: 3000

Tanks: 0

82ND AIRBORNE DIVISION

A pre-war regular army division stationed at Fort Bragg, North Carolina. The division moved by air to Saudi Arabia in late February of 1997. In May the division conducted an airborne assault on Bandar Khomeyni and successfully secured an airhead

and seahead for insertion of additional U.S. forces. The division then assumed the role of theater reserve and moved back to Saudi Arabia. In October, the division was dropped by air near Tabriz in northwestern Iran to isolate Soviet units in southern Iran. While U.S. and allied forces halted the Soviet drive further south, the 82nd Airborne fought a number of skillful holding actions against Soviet and allied forces from the north. By late October, the division was ordered to withdraw overland to Bandar Khomeyni. The division linked up with Kurdish irregulars near Orum-lyeh and then moved south through Bakhtaran and Ahvaz to the coast. Resupply and casualty evacuation were carried out by corps helicopter assets throughout. The division linked up with friendly forces on 1/1/98 after having suffered heavy casualties en route but retaining its cohesion and combat effectiveness throughout. The division was then evacuated to Saudi Arabia to rest and refit. In the spring of 1998 the division was again committed to combat in central Iran near Shiras where it fought a series of sweeps and raids to clear the area of armed bands. In December of 1999 the division moved to Bandar Khomeyni where it relieved the 24th Infantry Division (Mechanized) and took over the defense of the city.

Subordination: XVIII US Airborne Corps
Current Location: Iran
Manpower: 3000
Tanks: 7 LAV-75

84TH INFANTRY DIVISION (Light)

The division was formed on 7/20/98 by redesignation of the 84th Training Division (U.S. Army Reserve) in Milwaukee, Wisconsin. The division was employed in a variety of internal security and disaster relief missions throughout 1998 and early 1999. In August of 1999 the division was ordered to prepare to move south to reinforce the 5th Army in Arkansas, Oklahoma and Louisiana. Instead, the division commander placed the personnel of the division at the disposal of V Military Region Headquarters (U.S. Civilian Government).

Subordination: V Military Region
Current Location: United States Northern Plains
Manpower: 4000
Tanks: 0

85TH INFANTRY DIVISION (Light) (1st Brigade)

The division was formed in Chicago, Illinois on 7/20/98 by redesignation of the 85th Training Division (U.S. Army Reserve). The division began immediately to move by road and river to Camp Beauregard, Louisiana, where it took over local security duties in western Louisiana. In late 1998 the division moved west into Texas and came into conflict with scattered elements of the Mexican Army and numerous armed bands. On 1/17/99 the division fought a major engagement with the "Texian National Legion" that resulted in it being surrounded and virtually annihilated. In mid-1999, the survivors of the division re-formed at Camp Beauregard as a single brigade.

Subordination: 122nd US Corps
Current Location: Southwestern U.S.
Manpower: 400
Tanks: 0

91ST INFANTRY DIVISION (Light) (3rd Brigade)

The division was formed in Sausalito, California on 7/20/98 by redesignation of the 91st Training Division (U.S. Army Reserve). The division was quickly engaged in heavy fighting

with mechanized elements of the Mexican Army and suffered heavy losses in a series of retrograde movements north. In November the division was cut off from the main body of the 89th Corps and virtually annihilated. In early 1999, the survivors of the division were reformed in central California as a single brigade.

Subordination: 89th US Corps
Current Location: California
Manpower: 600
Tanks: 0

95TH INFANTRY DIVISION (Light)

The division was formed at Livonia, Michigan on 7/20/98 by redesignation of the 95th Training Division (U.S. Army Reserve). The division immediately began moving by road to Illinois for transfer to the Southwestern Theater. The division arrived at Fort Chaffee, Arkansas on 11/1/98 and came under the command of 90th US Corps, then engaged against elements of the Mexican Army and various armed bands in northern Texas and southern Oklahoma. By January of 1999 the division was involved in combat against elements of the "Texian National Legion" in northeast Texas and then participated in 5th Army's drive to clear Texas of marauders and paramilitary bands. Following the defeat of 49th Armored Division by the Soviet "Division Cuba", the 95th division fought a series of skillful rearward actions covering the withdrawal of 90th Corps into Oklahoma.

Subordination: 90th US Corps
Current Location: Oklahoma
Manpower: 4000
Tanks: 3 M60A4

98TH INFANTRY DIVISION (Light) (2nd Brigade)

The division was formed in Midwest City, Oklahoma on 7/20/98 by redesignation of the 98th Training Division (U.S. Army Reserve) and undertook a variety of internal security and riot suppression missions in southern Oklahoma and northern Texas. On 9/17/98 outposts of the division came under attack by advanced elements of the Mexican 3rd Armored Cavalry Regiment and soon became embroiled in a series of running clashes with this and other forward elements of the Mexican Army. Caught between Mexican units to the south and marauders to the north, the division withdrew under heavy pressure into Louisiana, at which time it came under command of the 122nd US Corps. The 1500 survivors of the division were reformed as a single brigade, but were later considerably reinforced by absorbing a number of local militia units.

Subordination: 122nd US Corps
Current Location: Louisiana
Manpower: 3000
Tanks: 4 M60A4

100TH INFANTRY DIVISION (Light)

The division was formed in Louisville, Kentucky on 7/20/98 by redesignation of the 100th Training Division (U.S. Army Reserve). The division immediately began to move by river and road to Fort Sill, Oklahoma where it came under command of 90th US Corps. The division participated in local security missions throughout 1998 and covered the right flank of 5th Army during its drive into central and southern Texas in 1999. Following the defeat of the 49th Armored Division and the general withdrawal of 5th Army, the division became isolated

from the main body of 90th Corps and withdrew north to Fort Carson, Colorado.

Subordination: Strategic reserve

Current Location: Fort Carson, Colorado

Manpower: 5000

Tanks: 4 M60A4

1 M1

1 M1A1

101ST AIR ASSAULT DIVISION

A pre-war regular army division stationed at Fort Campbell, Kentucky. The division moved by air to Saudi Arabia in March of 1997 and in May conducted a successful airmobile assault on Bushehr, securing an airhead and seahead for insertion of additional U.S. troops. Within a month the division was heavily involved in fluid combat in central Iran against Soviet air assault and mechanized forces. The division, in conjunction with the 6th Cavalry Brigade (Air Combat), constituted the 3rd Army's rearguard in its retreat back to the coast. Throughout November and December aviation assets of the division conducted continuous resupply and aerial fire support missions in support of the 82nd Airborne Division, while ground elements of the division moved back and took over the defense of Bushehr. In January of 1998 the aviation elements of the division were withdrawn to Saudi Arabia to rest and refit. The division was reunited in March of that year at Bushehr and took part in the clearing operations in the Bushehr-Shiras-Bandar 'Abbas triangle.

Subordination: XVIII US Corps

Current Location: Iran

Manpower: 4000

Tanks: 0

Aircraft: 4 AH-64

104TH INFANTRY DIVISION (Light)

The division was formed at Vancouver, Washington on 7/20/98 by redesignation of the 104th Training Division (U.S. Army Reserve). Upon activation, the division came under command of VIII US Corps and on 8/2/98 entered combat against Soviet forces attacking the Fort Lawton area from the north. By late August, the situation was stabilized and the division was withdrawn from the front line to take over internal security duties in the Montana-Idaho region.

Subordination: VIII US Corps

Current Location: Pacific Northwest

Manpower: 4000

Tanks: 1 M728 Combat Engineer Vehicle

1 Stingray

1 M60A4

1 M1A2

108TH INFANTRY DIVISION (Light)

The division was formed at Charlotte, North Carolina on 7/20/98 by redesignation of the 108th Training Division (U.S. Army Reserve). The division was assigned a variety of internal security and disaster relief missions in the southeastern United States. In mid-1999 the division experienced increasing friction with anti-government partisans in Mississippi, Alabama and Georgia. In September of that year the division evacuated Fort McClellan, Alabama and all posts west of there. The division now holds Forts Benning and Stewart in Georgia and Camp Blanding, Florida, as well as the general area between those three posts. This area is somewhat fancifully referred to in division



dispatches as "The Iron Triangle".

Subordination: III Military Region

Current Location: Southeastern United States

Manpower: 5000

Tanks: 4 M728 CEV

Marine Divisions

1ST MARINE DIVISION

A pre-war regular division stationed at Camp Pendleton, California. The division began moving to Saudi Arabia in March of 1997 and in June conducted a successful amphibious assault against Bandar 'Abbas, Iran. By summer the division had driven north and captured the airfield complex at Yazd but was heavily engaged by Soviet mechanized forces from the Turkestan Military District and Afghanistan. The division was able to repulse all attacks on its position, but on 8/1/97 the last supply road from Bandar 'Abbas to Yazd was cut and the division was forced to retire. The division successfully fought its way out of the encirclement and rejoined the main body of I Amphibious Corps north of Bandar 'Abbas on 9/17/97.

The division remained in the Bandar 'Abbas area throughout the remainder of 1997. In 1998 the division participated in the clearing operations in the Bushehr-Shiras-Bandar 'Abbas triangle and in 1999 undertook a number of search and destroy operations against armed bandit bands. In June of 2000, the division was withdrawn from Bandar 'Abbas and conducted a successful amphibious assault against Chah Bahar.

Subordination: I US Amphibious Corps

Current Location: Iran

Manpower: 3000

Tanks: 6 M1

2ND MARINE DIVISION

A pre-war regular division stationed at Camp Lejeune, North Carolina. The 6th Marine Regiment of the division deployed by air to Denmark in November of 1996. The 2nd Marine Regiment (reinforced) formed the main body of the 4th Marine Amphibious Brigade and deployed to Norway by air and sea in December of 1996. The main body of the 8th Marine Regiment moved by sea to the Mediterranean Sea to join forward elements of the

regiment then serving with the Sixth Fleet.

During 1997, the regiment's of the division carried out numerous amphibious and conventional missions throughout the European Theater. In October of that year, the 4th MAB was moved south to the Baltic and disbanded, its component units reverting to division control along with the 6th Regiment. In January of 1998, the survivors of the 8th Marine Regiment reformed in northern Germany and were also reunited with the division. In Spring of 2000, the division participated in Third German Army's offensive into northern Poland by launching amphibious assaults against the Polish Baltic coast and across the estuary of the Vistula (Wisla). The divisions present status and location are unknown.

Subordination: US XI Corps

Current Location: Northern Poland

Manpower: 4000

Tanks: 8 M1

3RD MARINE DIVISION

A pre-war regular division stationed on Okinawa. The division began moving to Saudi Arabia in April of 1997 and came under command of I Amphibious Corps. In June the division joined the 1st Marine Division in the Bandar 'Abbas beachhead and by July had linked up with elements of the US XVIII Corps at Shivas. By then the division was heavily engaged by Soviet air assault and mechanized forces and was ordered to withdraw to Bandar 'Abbas to protect the supply line to 1st Marine Division, then at Yazd. The division held Bandar 'Abbas with difficulty and provided limited assistance to cover the withdrawal of 1st Marine Division. By the end of September, the two divisions had linked up and enemy attacks abated for lack of supply. The division has remained in the general area of Bandar 'Abbas since then, providing security for the port and airfield and conducting numerous search and destroy missions against bandits, marauder bands and Soviet units.

Subordination: I US Amphibious Corps

Current Location: Iran

Manpower: 4000

Tanks: 5 M1

23RD MARINE REGIMENT, 4TH MARINE DIVISION

A pre-war USMC Reserve division stationed at New Orleans, Louisiana. The division was mobilized on 10/5/96 and became fully operational on 11/7/96, at which time it moved by sea to Pearl Harbor, Hawaii. On 2/5/97 the division moved by sea to Yokosuka, Japan, and by the end of February had moved by sea and air to Seoul, Korea, at which time it came under command of II US Corps. On 3/8/97 it first entered combat against the North Korean Army. In September of 1997 (by which time the division was serving under command of II US Amphibious Corps), the division suffered heavy casualties from tactical nuclear strikes and was withdrawn from the front lines to reform. The survivors of the division were reformed around the 23rd Marine Regiment and excess command and support personnel were returned to the United States to serve as the cadre for an additional Marine division.

Subordination: II US Amphibious Corps

Current Location: Korea

Manpower: 400

Tanks: 7 M60A4



5TH MARINE DIVISION

The division was activated on 2/31/97 at Camp Lejeune, North Carolina, and was declared fully operational on 7/18/97. On 8/2/97 it began to deploy to Korea by air and sea, and on 8/27/97 came under command of II US Amphibious Corps. It first entered combat on 8/30/97 against troops of the North Korean and Soviet armies.

Subordination: II US Amphibious Corps

Current Location: Korea

Manpower: 2000

Tanks: 9 M60A4

16TH REGIMENT, 6TH MARINE DIVISION

The division was activated on 11/6/97 using surviving personnel of the 4th Marine Division as a command and training cadre. The division was declared operational on 2/19/98 and began deploying to Korea by sea. The division suffered serious casualties en route from Soviet air attack and commerce raiders, and upon arrival in Korea the survivors were reformed around the 16th Marine Regiment. The regiment first entered combat on 3/7/98.

Subordination: II US Amphibious Corps

Current Location: Korea

Manpower: 600

Tanks: 4 M60A4

Separate Brigades

1ST INFANTRY BRIGADE (Arctic Recon)

An Alaskan National Guard Brigade. The brigade came into federal service on 7/3/96 and assumed responsibility for local security and long range recon patrols along the Bering Straits. Throughout the last half of 1996 and the first half of 1997, the brigade mounted aggressive deep patrols across the Bering Strait into Soviet territory and fought numerous small actions with Soviet arctic forces. In June of 1997 the brigade repulsed a number of Soviet commando raids across the strait but was forced to withdraw westward after Soviet arctic mechanized units crossed to the U.S. side. The brigade abandoned Anchorage in July and withdrew to Fort Wainwright where it came under command of the newly-formed X US Corps. For the rest of 1997

the brigade held off numerous Soviet attacks on the X Corps lodgement area and in early 1998 participated in the corps' counteroffensive. In March the brigade participated in the recapture of Fairbanks and in April drove west to Kayukak, cutting the Soviet direct supply line across the Bering Strait. As the logistical situation continued to deteriorate in the north, the brigade dispersed into small self-sufficient hunting/raiding parties that continue to range both sides of the straits.

Subordination: X US Corps

Current Location: Alaska

Manpower: 400

Tanks: 0

2ND INFANTRY BRIGADE (Arctic Recon)

An Alaskan National Guard Brigade. The brigade came into federal service on 7/3/96 as the 207th Infantry Group (scout), and was redesignated the 2nd Infantry Brigade (Arctic Recon) on 7/5/96. The brigade assumed responsibility for local security in the Aleutians in August and remained there until June of 1997. At that time the brigade returned to Anchorage and then moved north overland to Anchorage where it joined the 1st Infantry Brigade (Arctic Recon). In July the brigade retreated east to Fort Greely and upon arrival came under the command of the newly-formed X US Corps. For the rest of 1997, the brigade held off numerous Soviet attacks on the X Corps lodgement area and in early 1998 participated in the corps' counteroffensive. In March the brigade participated in the recapture of Fairbanks and in April drove south with 10th Infantry Division (Mountain) to the Anchorage area. In late 1998, the brigade left the Anchorage area and drove southeast toward Juneau. On 12/25/98 the brigade recaptured Juneau by assault, suffering heavy casualties in the process but considerably aided by local partisans. The brigade then took over local security for the Juneau logistical hub.

Subordination: X US Corps

Current Location: Alaska

Manpower: 300

Tanks: 0

6TH AIR CAVALRY COMBAT BRIGADE

A pre-war regular brigade stationed at Fort Hood, Texas, under the command of III Corps. On 3/1/97 the brigade was assigned to XVIII Corps and shortly thereafter began deploying by air to Saudi Arabia. In June the brigade was temporarily attached to 82nd Airborne Division to support the airborne assault on Bandar Khomeyni. In July the brigade was shifted to Bushehr and supported the drive north against Esfahan. By August the brigade had suffered considerable attrition due both to enemy action and mechanical failure and, as a result, was withdrawn to Saudi Arabia to rest and refit. In October the brigade deployed forward to Bandar Khomeyni and for the next two months conducted aerial fire support and resupply escort missions in support of the overland withdrawal of 82nd Airborne Division from Tabriz. In March of 1998, the brigade was again withdrawn to rest but was returned to action in mid-year to support the clearing operations in the Bushehr-Shiras-Bandar 'Abbas triangle. By the end of the year the brigade had moved back to Bandar Khomeyni to support the defense of the Abadan-Ahvuz-Bandar Khomeyni area. In mid-1999 the brigade absorbed all remaining operational helicopter gunships of the 24th and 82nd Divisions.

Subordination: XVIII US Corps

Current Location: Iran

Manpower: 600

Tanks: 0

Aircraft: 12 AH-64

29TH INFANTRY BRIGADE

A Hawaii National Guard brigade which was brought into federal service on 8/25/96. The brigade has remained in Hawaii throughout the war carrying out a variety of internal security and disaster relief missions.

Subordination: ForceCom

Current Location: Hawaii

Manpower: 3000

Tanks: 8 M60A4

30TH ENGINEER BRIGADE (Combat)

A North Carolina National Guard brigade which was brought into federal service on 8/25/96. In November of 1996 the brigade moved to Fort A.P. Hill, Virginia and became responsible for engineering support tasks for units arriving in Virginia for shipment overseas. In 1997 the brigade was made responsible for emergency disaster relief and reconstruction of essential facilities in the III Military Region (Maryland, Delaware, Virginia, North Carolina and South Carolina). The SLBM strike on the Presidential Emergency Facilities at Fort Hill caused some casualties, but the brigade survived largely intact. In February of 1999 the brigade commander declared for the civilian government of the United States and the brigade came under command of III Military Region headquarters. Following this, the brigade concentrated at Fort Jackson, South Carolina and took over a variety of security and reconstruction tasks.

Subordination: III Military Region

Current Location: Fort Jackson, SC

Manpower: 2,000

Tanks: 6 M728 CEV

35TH ENGINEER BRIGADE (Combat)

A Missouri National Guard brigade which was brought into federal service on 8/25/96. In November of 1996 the brigade moved to Chicago, Illinois and became responsible for engineering support for movement to the Chicago port of embarkation of overseas-bound units. In 1997 the brigade took over a variety of security and reconstruction tasks in the Chicago metropolitan area, but late in the year evacuated the area and moved into down-state Illinois. In September of 1998 the brigade commander declared for the civilian government and at that time came under command of V Military Region (Illinois, Wisconsin, Minnesota, Missouri, Iowa). Following armed clashes with troops loyal to the military government, the brigade withdrew in company with the command personnel of V Military Region across the Mississippi River into Missouri, Iowa, and Nebraska. The bulk of the brigade now served as a security force for the U.S. Civilian Government capital at Omaha, Nebraska.

Subordination: V Military Region

Current Location: Omaha, NB

Manpower: 800

Tanks: 0

43RD MILITARY POLICE BRIGADE

A Rhode Island National Guard brigade which was brought into federal service on 8/25/96. In November of 1996 the brigade moved to Fort Devens, Massachusetts and became responsible for internal security and logistical movement in

Military Region I (New York and the New England states). In June of 1997 the brigade was made responsible for security and distribution of foodstuffs in Military Region I.

Subordination: XII US Corps
Current Location: East Coast
Manpower: 1400
Tanks: 0

49TH MILITARY POLICE BRIGADE

A California National Guard brigade which was brought into federal service on 8/20/96. In November of 1996 the brigade moved to San Diego, California and became responsible for traffic control in the area of the port of embarkation. In June of 1997 the brigade was made responsible for security and distribution of foodstuffs in the southern half of military region IX (California, Nevada and New Mexico). In September of 1997 the brigade reformed at Fort Irwin, California and came under command of the newly-formed 89th Corps. It was soon involved in combat with advanced elements of the Mexican Army and by the end of the year had been forced back to Camp Roberts, California.

Subordination: 89th US Corps
Current Location: California
Manpower: 700
Tanks: 0

184TH INFANTRY BRIGADE

A Mississippi National Guard brigade which was brought into federal service on 8/25/96 as the 184th Transportation Brigade. In November of 1996 the brigade moved to Richmond, VA and became responsible for logistical movement within the port of embarkation. In June of 1997 the brigade was made responsible for security and distribution of foodstuffs in military regions II (New Jersey, Pennsylvania, West Virginia) and III (Maryland, Delaware, Virginia, North Carolina, South Carolina). In September of 1997 the brigade was redesignated an infantry brigade and took over general security duties in III Military Region. In January of 1999 the brigade commander, in conjunction with the GOC (General Officer Commanding) III Military Region, declared in favor of the civilian government. In the spring of 1999 the brigade concentrated at Fort Bragg, North Carolina.

Subordination: III Military Region
Current Location: Fort Bragg, NC
Manpower: 1800
Tanks: 9

194TH ARMORED BRIGADE

A pre-war regular brigade stationed at Fort Knox, Kentucky. The brigade remained in the United States as part of a small strategic reserve until mid-1997. At that time, the brigade was made responsible for a variety of security and disaster relief missions in the Kentucky and Tennessee area. In August of 1999 the brigade was ordered north to combat the 84th Infantry Division, then in a state of mutiny, in Wisconsin. En route through Indiana, word was received of the mutiny of the 35th Engineer Brigade in Illinois. The brigade moved against the mutineers and, after a week of fruitless negotiation, attacked them. The brigade suffered few casualties in the action, but did not succeed in subduing the mutineers who withdrew across the Mississippi River. Rather than move north against the 84th Infantry, which was now rumored to be moving west as well, the brigade moved to southern Illinois where it established a logistical cantonment at the confluence of the Ohio and Mississippi Rivers.

Subordination: 5th US Army
Current Location: Cairo, Illinois
Manpower: 1600
Tanks: 7 M1
 18 M1A1
 11 M1A2

197TH INFANTRY BRIGADE (Mechanized)

A pre-war regular brigade stationed at Fort Benning, Georgia. The brigade remained in the United States as part of a small strategic reserve until mid-1997. At that time it was made responsible for a variety of security and disaster relief missions in the Georgia and Florida area. In September of 1998 the brigade was ordered west to reinforce the 5th Army. The brigade arrived in Louisiana in October and conducted a successful offensive against the Texian National Legion, breaking its grip on east Texas. In 1999 the brigade was involved in a number of operations against armed bands in the east Texas and western Louisiana area. In September the brigade was withdrawn from combat to rest and refit and then sent north to subdue Memphis, which was then in the grip of a feudal-style overlord who was disrupting river traffic on the Mississippi. The siege of Memphis lasted throughout the winter of 1999-2000, and the central city did not fall until May. The brigade was then assigned to garrison Memphis and establish it as a logistical base to support 5th Army.

Subordination: 5th Army
Current Location: Memphis
Manpower: 1500
Tanks: 13 M1A1

221ST MILITARY POLICE BRIGADE

A pre-war Army Reserve Brigade stationed in San Jose, California. The brigade was activated on 7/1/96 and deployed by sea to Honolulu, Hawaii. Upon arrival, the brigade assumed responsibility for security and traffic control in and near the Pearl Harbor naval base. In November of 1997 the brigade was made responsible for a variety of disaster relief tasks in the Hawaiian Islands. In June 1998 the brigade reembarked and moved to California by sea. Upon arrival it came under command of the 63rd Corps and was soon involved in combat with elements of the Mexican Army as well as bands of looters and secessionist partisans. The brigade has remained in central and southern California since then serving as combat infantry.

Subordination: 63rd US Corps
Current Location: California
Manpower: 700
Tanks: 0

228TH INFANTRY BRIGADE

A South Carolina National Guard brigade which was brought into federal service on 8/25/96 as the 228th Signal Brigade. In October of 1996 the brigade moved to Fort Meade, Maryland, and became responsible for all military signal traffic in First Army area. In June of 1997 the brigade was also made responsible for local security for the Fort Meade area. Because of the nature of these duties, the brigade was not badly damaged when Fort Meade was the target of a Soviet SLBM strike in November of 1997. In January of 1999, the brigade refused orders to relocate to Richmond, Virginia, with the headquarters element of First Army and declared in favor of the Civilian Government. At that time it came under command of III Military Region and

became responsible for local security in the Fort Meade area. In August of 1999 the brigade was redesignated 228th Infantry Brigade.

Subordination: III Military Region
Current Location: Vcty, Fort Meade, MD
Manpower: 1000
Tanks: 0

THE CADET BRIGADE

The Cadet Brigade was formed in January, 1988, from the cadets of the United States Air Force Academy in Colorado Springs, Colorado. The brigade took over the weapons and equipment left in Fort Collins by the 4th Infantry division when the 4th division was airlifted to Europe in October of 1996. In March of 1998, the Military Government moved its capital to Colorado Springs, and the Cadet Brigade now provides security parties for the joint chiefs. Detachments from the Cadet Brigade also share the duty of protecting the Fort St. Vrain Nuclear Power station (at Platteville, Colorado) with detachments of the 100th Infantry Division. In theory, the Cadet Brigade is part of the U.S. Air Force, but in practice there is no distinction between it and the other units of the Military Government.

Subordination: Strategic Reserve
Current Location: Colorado
Manpower: 900
Tanks: 2 M60A4

THE SCHOOL BRIGADE

A pre-war regular army brigade stationed at the U.S. Army Air Defense Center and School at Fort Bliss, Texas. The brigade served as a chain-of-command parent organization for a variety of training units assigned to the school for training and activation. With the outbreak of hostilities with Mexico in 1998, the brigade was activated as a troop unit, using its available mix of weapons to create unorthodox operational units. Infantry was drawn from basic training camps at Fort Bliss and attached to ADA gun batteries (PIVAD and Diana) to create heavy machinegun combat teams. Because the brigade had no organic field artillery, it relied heavily on infantry mortars and developed its own doctrine for employment of ADA gun systems in the indirect fire role.

The School Brigade was able to hold the Fort Bliss area against repeated attacks, but was soon surrounded. Fighting its way free of the encirclement, the brigade retreated north, evacuating its equipment, personnel, and dependents through New Mexico. Once across the Canadian River, the brigade linked up with elements of the 90th US Corps in Oklahoma. In January of 1999, the School Brigade was attached to 49th Armored Division, with which it has served since.

Subordination: 49th Armored Division
Location: Oklahoma
Manpower: 1,800
Tanks: 0

Armored Cavalry Regiments

2ND ARMORED CAVALRY REGIMENT

A pre-war regular army regiment stationed at Nürnberg, Germany under the command of VII US Corps. The regiment crossed the inter-German border on 12/3/96 and was engaged in combat against Soviet forces on 12/7/96. The regiment has par-



ticipated in every major offensive in Germany and Poland of the war.

Subordination: VII US Corps
Current Location: Central Germany
Manpower: 100
Tanks: 2 M1A2
 6 LAV-75

3RD ARMORED CAVALRY REGIMENT

A pre-war regular army regiment stationed at Fort Bliss, Texas, under command of III US Corps. The regiment was placed on alert in early October of 1996 and in early November began to deploy by air to Europe. The regiment left its heavy equipment at Fort Bliss and took over equipment stored at POMCUS sites in western Germany. Upon arrival in Germany, the regiment came under command of V US Corps, but on 11/30/96 reverted to command of III US Corps and began moving north by road. The regiment crossed the inter-German border on 12/7/96 and was engaged in combat against Soviet forces on 12/12/96. The regiment suffered heavy casualties while serving as rearguard during the retreat from Warsaw in September of 1997 and in December of 1997 was reformed as a single squadron.

Subordination: III US Corps
Current Location: Southern Germany
Manpower: 100
Tanks: 1 M1A1

11TH ARMORED CAVALRY REGIMENT

A pre-war regular army regiment stationed at Fulda under V US Corps. The division crossed the inter-German border on 12/2/96 and was engaged in combat against Soviet forces on 12/5/96. The regiment has engaged in every major offensive of the war in Germany and Poland.

Subordination: V US Corps
Current Location: Central Germany
Manpower: 500
Tanks: 4 M1A1

107TH ARMORED CAVALRY REGIMENT

An Ohio National Guard regiment, placed on alert on 12/3/96 and brought into federal service on 12/7/96. The regiment

transferred to Germany by sea and air in May of 1997 as part of the IX US Corps and entered combat in Poland on 5/31/97. In September of 1997, while fighting a rearguard action covering the retreat of IX Corps, the regiment was surrounded by elements of the Soviet 3rd Guards Shock Army. The regiment was forced to abandon all vehicles and make its way out on foot, but the extreme courage and resourcefulness of the troops of the regiment enabled large numbers of men to rejoin the NATO forces near the German frontier. The regiment has since operated as horse cavalry.

Subordination: XXIII US Corps

Current Location: Austria

Manpower: 600

Tanks: 0

116TH ARMORED CAVALRY REGIMENT

Idaho National Guard. The regiment was alerted on 1/12/96 and brought into federal service on 4/1/96. The regiment deployed to Germany by air and sea in August of 1996 and upon arrival came under command of IX US Corps. During the retreat from Warsaw in September 1997 the regiment fought numerous rearguard actions and took heavy casualties, but maintained its cohesion throughout the retreat. In May of 1999 the regiment was transferred to XI US Corps and participated in the summer offensive of 2000 into northern Poland.

Subordination: XI US Corps

Current Location: northern Poland

Manpower: 600

Tanks: 8 LAV-75

163RD ARMORED CAVALRY REGIMENT

Montana National Guard (except for the 3rd Squadron, which is a Texas National Guard unit). The regiment entered federal service on 11/1/96 and began moving by sea to Korea in early

1997. Upon arrival the regiment came under command of VI Corps and participated in holding actions along the 38th parallel and then the general offensive of 8th Army toward the Yalu River. In the subsequent retreat back to central Korea, the regiment suffered heavy casualties while fighting a series of stubborn rearguard actions.

Subordination: VI US Corps

Current Location: Korea

Manpower: 300

Tanks: 4 LAV-75

278TH ARMORED CAVALRY REGIMENT

A Tennessee National Guard regiment, placed on alert on 8/21/96 and brought into federal service on 11/1/96. It was deployed by air and sea to Germany in January of 1997, but suffered almost 50% equipment losses in transit to Soviet commerce raiders. Upon arrival in Germany, the regiment's 2nd squadron was fully equipped and sent into combat with V US Corps, while the bulk of the regiment awaited re-equipment. As losses mounted at the front, however, the bulk of the replacement equipment arriving in-theater was allocated to regular army units. As an expedient, the first and third squadrons were made mobile with requisitioned civilian motor vehicles and a large number of armored cars transferred from U.S. Air Force airfield security units, and was then committed to reinforce I US Corps. On 7/21/97 the 2nd Squadron, serving with V US Corps, was nearly annihilated by a tactical nuclear strike, and surviving personnel were returned to the regiment. By the end of 1997, the regiment was operating as a single composite squadron.

Subordination: I US Corps

Current Location: Central Germany

Manpower: 400

Tanks: 0



Organization

This chapter deals with the authorized strengths of major Army and Marine Corps units during the war. This can be used as a general guide to the types of vehicles still present in the unit. However, in many cases combat losses were replaced with vehicles and weapons not originally authorized for the unit, and in the late 1990s it became quite common for small parties separated from their parent unit to be absorbed into whatever unit was in their vicinity. Thus, by 2000 almost any type of vehicle or weapon could be found in a unit.

The chapter is divided into two parts. First, there is a listing of the major combat vehicle and principal weapons authorized for a variety of the most common combat battalions in the Army and Marines. These authorization levels were generally based on the Tables of Organization and Equipment (TO&E) adopted in September of 1994. In many cases these are similar to those in use in the 1980s, but some differences are present.

The second part of the chapter consists of charts showing the major combat battalions and batteries in every Army and Marine division as well as certain selected non-divisional units. This represents the actual battalions assigned to the division at the outbreak of the war or, in the case of those divisions formed after the outbreak of hostilities, its strength when formed.

The following abbreviations are used in the TO&E listings below:

AAVP: Armored Amphibious assault Vehicle, Personnel
ACCV: Armored Cavalry Combat Vehicle
ADA: Air Defense Artillery
AH: Attack Helicopter
APC: Armored Personnel Carrier
FAV: Fast Attack Vehicle
LAV: Light Armored Vehicle
LAVAA: Light Armored Vehicle, Antiarmor
MPGS: Mobile Protected Gun System
OH: Observation Helicopter

SP: Self-Propelled Gun

UH: Utility Helicopter

Authorized Levels of Principal Combat Vehicles & Weapons

TANK BATTALION

Headquarters Company:

2 tanks (command)
 4 M577A1 (staff)
 6 CFV or ACCV (scout platoon)
 6 mortars (mortar platoon)
 6 Stingers (ADA platoon)

Four Tank Companies, each:

14 tanks.

Note: Specific equipment varied from battalion to battalion. In general, battalions equipped with M1, M1A1 and M1A2 tanks used the M3 CFV in the scout platoon and the M18 mortar vehicle in the mortar platoon. Battalions equipped with the M60A4 used the M113A3 ACCV in the scout platoon and M106 mortar carriers in the mortar platoon.

MECHANIZED BATTALION

Headquarters Company:

2 IFV or APC (command)
 4 M577A1 (staff)
 6 CFV or ACCV (scout platoon)
 6 mortars (mortar platoon)
 6 Stingers (ADA Platoon)

Antiarmor Company:

4 IFV or APC
 12 antiarmor vehicles

Four Infantry Companies, each:

14 IFV or APC
 9 tank breakers (1 per squad)

Note: Equipment varied from battalion to battalion. In general, regular army battalions were equipped with M2 Bradleys, M920

antiarmor vehicles, M3s, and M18 mortar carriers. National guard battalions with M2s were similar except that the antiarmor company was equipped with M113A3 APCs and M901 antiarmor vehicles. National Guard battalions with M113A3 APCs used M113A3 ACCVs in the scout platoon, M109 mortar carriers in the mortar platoon and M901 antiarmor vehicles in the antiarmor company.

LIGHT INFANTRY BATTALION

Headquarters Company
 Combat Support Company:
 10 FAV (scout platoon)
 6 Stingers (ADA platoon)
 4 4.2" mortars
 16 HMMWV with TOW II
 3 Rifle Companies, each:
 2 HMMWV with TOW II (weapons platoon)
 3 81mm mortars (weapons platoon)
 9 Tank Breakers (1 per squad)

LIGHT ATTACK BATTALION

Headquarters Company
 Combat Support Company:
 10 FAV (scout platoon)
 6 120mm mortars (mortar platoon)
 6 Stingers (ADA platoon)
 6 HMMWV with TOW II
 3 Light Attack Companies
 6 HMMWV
 21 FAV
 9 TOW II (1 per squad)

LIGHT MOTORIZED BATTALION

Headquarters Company:
 10 FAV (scout platoon)
 6 120mm mortars (mortar platoon)
 6 Stingers (ADA platoon)
 Antiarmor Company
 12 HMMWV with TOW II
 6 LAVAA with TOW II
 6 HMMWV fire support vehicles
 2 Light Motorized Companies, each:
 23 HMMWV
 6 Tank Breakers (2 per platoon)
 1 Heavy Motorized Company:
 14 LAV-25
 6 Tank Breakers (2 per platoon)

LIGHT TANK/ASSAULT GUN BATTALION

Headquarters Company:
 2 LAV-75 (command)
 10 FAV (scout platoon)
 6 M18 mortar carriers (mortar platoon)
 6 Stingers (ADA platoon)
 3 Companies, each:
 13 LAV-75

FIELD ARTILLERY BATTALION

Headquarters Company:
 5 M577A1 (staff)
 3 Firing Batteries, each:
 8 towed or self-propelled howitzers (4 per platoon)

Note: Firing batteries are equipped with either 105mm or 155mm howitzers.

FIELD ARTILLERY ROCKET BATTERY

2 M577A1
 6 multiple rocket launchers
Note: Multiple rocket launchers could be either MLRS or LARS.

ATTACK HELICOPTER BATTALION

Headquarters Company:
 6 UH-60 (command)
 6 OH-58 (liaison)
 3 Attack Helicopter Companies, each:
 4 OH-58
 7 AH
 Support Company:
 16 UH-60 (logistical support)
Note: AH could be either AH-1 or AH-64.

AIR CAVALRY SQUADRON

Headquarters Troop:
 6 UH-60 (command)
 6 OH-58 (liaison)
 2 Air Cavalry Troops, each:
 6 OH-58
 4 AH
 2 Attack Helicopter Troops, each:
 4 OH-58
 7 AH
 Support Troop:
 16 UH-60 (logistical support)
Note: AH could be either AH-1 or AH-64.

ARMORED CAVALRY SQUADRON

Headquarters Troop:
 2 tanks (command)
 4 M577A1 (staff)
 3 AVLB (bridge section)
 3 Cavalry Troops, each:
 1 M577A1
 2 mortar carriers
 9 tanks
 12 CFV or ACCV
 Tank Company:
 14 tanks

Note: Equipment varied from squadron to squadron. In general, M3 CFV squadrons were equipped with M1 tanks and M18 mortar carriers. M113A3 ACCV squadrons were equipped with M60A4 tanks in the tank company, LAV-75 light tanks in the cavalry troops and M106 mortar carriers. M115A1 ACCV squadrons were equipped with LAV-75 light tanks throughout the squadron and M106 mortar carriers.

DIVISIONAL CAVALRY SQUADRON

Headquarters Troop:
 2 CFV or ACCV (command)
 4 M577A1 (staff)
 9 IFV or APC (NBC recon platoon)
 2 Cavalry Troops, each:
 1 M577A1
 3 mortar carriers (mortar section)
 19 CFV or ACCV



- 2 Air Cavalry Troops, each:
 - 6 OH58
 - 4 AH

Note: Equipment varied from squadron to squadron. In general, squadrons with M3 CFVs used the M18 mortar carrier and the AH-64 attack helicopter. Squadrons with M113A3 ACCVs used the M106 mortar carrier and the AH-1 attack helicopter. Squadrons equipped with the LAV-25 used the M106 mortar carrier and did not have attack helicopters, as these squadrons consisted of three cavalry troops and no air cavalry troop.

ADA BATTALION

- Headquarters Company
- 2 Gun Batteries, each:
 - 5 M113A3 APCs (command)
 - 12 SP or towed ADA guns
 - 28 Stingers
- 2 Missile Batteries, each:
 - 5 M113A3 APCs (command)
 - 12 SP ADA missiles

Notes: Equipment varied from battalion to battalion. The accompanying table lists the gun type that equipped the battalion followed by the missile type.

MARINE INFANTRY BATTALION

- Headquarters Company
- Combat Support Company:
 - 8 M106 mortar carriers (mortar platoon)
 - 8 HMMWV with TOW II (antitank platoon)
 - 6 Stingers (air defense platoon)
- 4 Marine Rifle Companies, each:
 - 6 60mm mortars (weapons platoon)
 - 4 Tank Breakers (weapons platoon)

MARINE RECON BATTALION

- Headquarters Company:
 - 4 Stingers (air defense platoon)
- 4 Recon Companies
 - 6 60mm mortars (2 per platoon)
 - 3 Tank Breakers (1 per platoon)

MARINE AMPHIBIOUS TRACTOR BATTALION

Total of 50 AAVP9

MARINE LAV-25 BATTALION

- Headquarters Company:
 - 2 LAV-25 (command)
 - 4 M577A1 (staff)
- Combat Support Company:
 - 8 M106 mortar carriers (mortar platoon)
 - 8 LAVAA with TOW II (antitank platoon)
 - 6 Stingers (air defense platoon)
- 1 Fire Support Company
 - 14 MPGS-90
- 3 Marine Rifle Companies, each:
 - 6 60mm mortars (weapons platoon)
 - 4 Tank Breakers (weapons platoon)
 - 16 LAV-25

MARINE ANTIARMOR COMPANY

- 4 M113A3 APC
- 18 M901 antiarmor vehicles

Components of Divisions and Selected non-Divisional Units

COMPOSITIONS OF MARINE DIVISIONS

	M1	M60A4	Marine Inf	LAV-25	Recon	155mm (towed)	155mm (SP)	105mm (towed)
1 Marine Div	1		8	1	1	2	1	
2 Marine Div	1		8	1	1	2	1	
3 Marine Div	1		8	1	1	2	1	
4 Mar Div		1	8	1	1	2	1	
5 Mar Div		1	9		1	3		
6 Mar Div		1	9		1	1		2

Note: A Marine Division normally had an antiarmor company attached as well. If engaged in amphibious operations, it would also have one or more amphibious tractor battalions attached.

Compositions of Army Divisions and Selected Non-Divisional Units

	M60A4	M1	M1A1	M1A2	LAV-75	Inf (M113)	Inf (M2)	Inf (M2A3)	Inf (foot)	Lt Motorized	Lt Attack	Cav (M3)	Cav (M113)	Cav (LAV-25)	Arm Cav (M3)	Arm Cav (M113)	Arm Cav (M115)	Air Cav (AH1)	Air Cav (AH64)	AH64	AH1	UH60	105mm (towed)	155mm (towed)	155mm (SP)	MLRS	LARS	M691/ADATS	M990/ADATS	M988/Roland	Towed PIVAD/Roland	LAV PIVAD/Roland	M741/Chapparral		
1 Arm Div	-	1	3	2	-	-	3	1	-	-	-	1	-	-	-	-	-	-	-	1	-	-	-	-	3	1	-	-	-	-	-	-	-	-	
1 Cav Div	-	2	2	2	-	-	3	1	-	-	-	1	-	-	-	-	-	-	-	1	-	-	-	-	3	1	-	-	-	-	-	-	-	-	
1 Inf Div (M)	-	1	2	1	-	-	5	1	-	-	-	1	-	-	-	-	-	-	-	-	1	-	-	-	3	1	-	-	-	-	-	-	-	-	
2 Arm Div	-	1	3	2	-	-	3	1	-	-	-	1	-	-	-	-	-	-	-	1	-	-	-	-	3	1	-	-	-	-	-	-	-	-	
2 Inf Div	-	2	-	-	-	-	2	-	-	6	-	-	-	-	-	-	-	-	-	1	1	-	1	-	3	1	-	-	-	-	-	-	-	1	
3 Arm Div	-	1	3	2	-	-	3	1	-	-	-	1	-	-	-	-	-	-	-	1	-	-	-	-	3	1	-	-	-	-	-	-	-	-	
3 Inf Div (M)	-	1	2	1	-	-	5	1	-	-	-	1	-	-	-	-	-	-	-	1	-	-	-	-	3	1	-	-	-	-	-	-	-	-	
4 Inf Div (M)	-	1	2	1	-	-	5	1	-	-	-	1	-	-	-	-	-	-	-	1	-	-	-	-	3	1	-	-	-	-	-	-	-	-	
5 Inf Div (M)	-	2	1	1	-	-	5	1	-	-	-	1	-	-	-	-	-	-	-	1	-	-	-	-	3	1	-	-	-	-	-	-	-	-	
6 Inf Div (L)	-	-	-	-	1	-	-	-	7	1	-	-	-	-	-	-	-	-	-	1	1	-	1	-	-	1	-	-	-	-	-	-	1	-	
7 Inf Div (L)	-	-	-	-	1	-	-	-	7	1	-	-	-	-	-	-	-	-	-	1	1	-	1	3	-	-	1	-	-	-	-	-	1	-	
8 Inf Div (M)	-	1	2	1	-	-	5	1	-	-	-	1	-	-	-	-	-	-	-	1	1	-	-	-	3	1	-	-	-	-	-	-	-	-	
9 Inf Div (Lm)	-	-	-	-	2	-	-	-	5	2	-	-	-	-	-	-	-	-	-	1	1	-	-	3	-	-	1	-	-	-	-	1	-	-	
10 Inf Div (L)	-	-	-	-	1	-	-	-	7	1	-	-	-	-	-	-	-	-	-	1	1	-	1	3	-	-	1	-	-	-	-	-	1	-	
24 Inf Div	-	2	1	1	-	-	5	1	-	-	-	1	-	-	-	-	-	-	-	1	1	-	1	-	3	1	-	-	-	-	-	-	-	-	
25 Inf Div (L)	-	-	-	-	1	-	-	-	7	1	-	-	-	-	-	-	-	-	-	1	1	-	1	3	-	-	1	-	-	-	-	-	1	-	
26 Inf Div (L)	-	-	-	-	1	-	-	-	7	1	-	-	-	-	-	-	-	-	-	1	1	-	1	3	-	-	1	-	-	-	-	-	1	-	
28 Inf Div	1	-	-	-	-	2	-	-	7	-	-	-	-	-	-	-	-	-	1	-	-	1	1	2	1	1	-	-	-	-	-	-	-	1	
35 Inf Div (M)	-	3	1	-	-	-	6	-	-	-	-	-	1	-	-	-	-	-	-	-	1	-	-	-	3	1	-	-	-	-	-	-	-	-	
36 Inf Div (M)	2	2	-	-	-	4	2	-	-	-	-	-	-	1	-	-	-	-	-	-	-	-	-	-	3	-	-	-	-	-	-	-	-	1	
38 Inf Div	1	-	-	-	-	2	-	-	7	-	-	-	-	-	-	-	-	-	1	-	-	1	1	2	1	1	-	-	-	-	-	-	-	1	
40 Inf Div (M)	2	2	-	-	-	4	2	-	-	-	-	-	1	-	-	-	-	-	-	-	-	1	1	-	3	1	-	-	-	-	-	-	-	-	
41 Inf Div	1	-	-	-	-	2	-	-	7	-	-	-	-	-	-	-	-	-	1	-	-	1	1	-	2	1	1	-	-	-	-	-	-	1	
42 Inf Div	1	-	-	-	-	2	-	-	7	-	-	-	-	-	-	-	-	-	1	-	-	1	1	-	2	1	1	-	-	-	-	-	-	1	
43 Inf Div	1	-	-	-	-	2	-	-	7	-	-	-	-	-	-	-	-	-	1	-	-	1	1	-	2	1	1	-	-	-	-	-	-	1	
44 Arm Div	1	3	1	-	-	2	2	-	-	-	-	-	-	1	-	-	-	-	-	-	-	-	-	-	3	-	-	-	-	-	-	-	-	1	
45 Inf Div	1	-	-	-	-	2	2	-	7	-	-	-	-	-	-	-	-	-	-	1	-	-	1	1	2	1	1	-	-	-	-	-	-	1	
46 Inf Div	1	-	-	-	-	2	-	-	7	-	-	-	-	-	-	-	-	-	-	1	-	-	1	1	2	1	1	-	-	-	-	-	-	1	
47 Inf Div	1	-	-	-	-	2	-	-	7	-	-	-	-	-	-	-	-	-	-	1	-	-	1	1	2	1	1	-	-	-	-	-	-	1	
49 Arm Div	1	2	2	-	-	2	2	-	-	-	-	-	1	-	-	-	-	-	-	-	-	1	-	-	3	1	-	-	-	-	-	-	-	-	
50 Arm Div	1	2	2	-	-	2	2	-	-	-	-	-	1	-	-	-	-	-	-	-	-	1	-	-	3	1	-	-	-	-	-	-	-	-	
70 Inf Div (L)	-	-	-	-	-	-	-	-	9	-	-	-	-	-	-	-	-	-	-	-	-	-	-	3	-	-	-	-	-	-	-	-	-	-	
76 Inf Div (L)	-	-	-	-	-	-	-	-	9	-	-	-	-	-	-	-	-	-	-	-	-	-	-	3	-	-	-	-	-	-	-	-	-	-	-
78 Inf Div (L)	-	-	-	-	-	-	-	-	9	-	-	-	-	-	-	-	-	-	-	-	-	-	-	3	-	-	-	-	-	-	-	-	-	-	-
80 Inf Div (L)	-	-	-	-	-	-	-	-	9	-	-	-	-	-	-	-	-	-	-	-	-	-	-	3	-	-	-	-	-	-	-	-	-	-	-
82 ABN Div	-	-	-	-	1	-	-	-	9	-	-	-	-	-	-	-	-	-	1	1	-	-	-	3	-	-	1	-	-	-	-	-	-	1	-
84 Inf Div (L)	-	-	-	-	-	-	-	-	9	-	-	-	-	-	-	-	-	-	-	-	-	-	-	3	-	-	-	-	-	-	-	-	-	-	-
85 Inf Div (L)	-	-	-	-	-	-	-	-	9	-	-	-	-	-	-	-	-	-	-	-	-	-	-	3	-	-	-	-	-	-	-	-	-	-	-
91 Inf Div (L)	-	-	-	-	-	-	-	-	9	-	-	-	-	-	-	-	-	-	-	-	-	-	-	3	-	-	-	-	-	-	-	-	-	-	-
95 Inf Div (L)	-	-	-	-	-	-	-	-	9	-	-	-	-	-	-	-	-	-	-	-	-	-	-	3	-	-	-	-	-	-	-	-	-	-	-
98 Inf Div (L)	-	-	-	-	-	-	-	-	9	-	-	-	-	-	-	-	-	-	-	-	-	-	-	3	-	-	-	-	-	-	-	-	-	-	-
100 Inf Div (L)	-	-	-	-	-	-	-	-	9	-	-	-	-	-	-	-	-	-	-	-	-	-	-	3	-	-	-	-	-	-	-	-	-	-	-
101 AAD Div	-	-	-	-	-	-	-	-	9	-	-	-	-	-	-	-	-	-	-	1	1	-	3	3	-	-	1	-	-	-	-	-	-	1	-
104 Inf Div (L)	-	-	-	-	-	-	-	-	9	-	-	-	-	-	-	-	-	-	-	-	-	-	-	3	-	-	-	-	-	-	-	-	-	-	-
108 Inf Div (L)	-	-	-	-	-	-	-	-	9	-	-	-	-	-	-	-	-	-	-	-	-	-	-	3	-	-	-	-	-	-	-	-	-	-	-
6 ACCB	-	-	-	-	-	-	-	-	-	-	-	-	-	-	-	-	-	-	-	1	2	-	-	-	-	1	-	-	-	-	-	-	-	-	-
194 Arm Bde	-	1	1	1	-	-	1	-	-	-	-	-	-	-	-	-	-	-	-	-	-	-	-	-	-	-	-	-	-	-	-	-	-	-	-
197 Inf Bde (M)	-	-	1	-	-	-	2	1	-	-	-	-	-	-	-	-	-	-	-	-	-	-	-	-	1	-	-	-	-	-	-	-	-	-	-
2 ACR	-	-	-	-	-	-	-	-	-	-	-	-	-	-	3	-	-	-	-	-	-	-	-	-	1	-	-	-	-	-	-	-	-	-	-
3 ACR	-	-	-	-	-	-	-	-	-	-	-	-	-	-	3	-	-	-	-	-	-	-	-	-	1	-	-	-	-	-	-	-	-	-	-
11 ACR	-	-	-	-	-	-	-	-	-	-	-	-	-	-	3	-	-	-	-	-	-	-	-	-	1	-	-	-	-	-	-	-	-	-	-
107 ACR	-	-	-	-	-	-	-	-	-	-	-	-	-	-	-	3	-	-	-	1	-	-	-	-	1	-	-	-	-	-	-	-	-	-	-
116 ACR	-	-	-	-	-	-	-	-	-	-	-	-	-	-	-	3	-	-	-	-	-	-	-	-	1	-	-	-	-	-	-	-	-	-	-
163 ACR	-	-	-	-	-	-	-	-	-	-	-	-	-	-	-	-	3	-	-	1	-	-	-	-	1	-	-	-	-	-	-	-	-	-	-
278 ACR	-	-	-	-	-	-	-	-	-	-	-	-	-	-	-	-	3	-	-	1	-	-	-	-	1	-	-	-	-	-	-	-	-	-	-

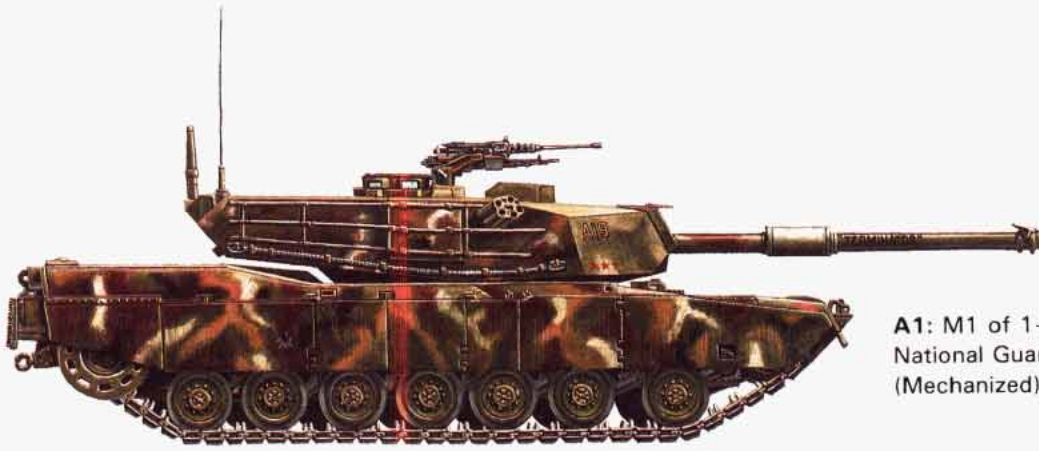

A1: M1 of 1-803 Armor (Washington National Guard), 36th Infantry Division (Mechanized); Poland, summer 1997.

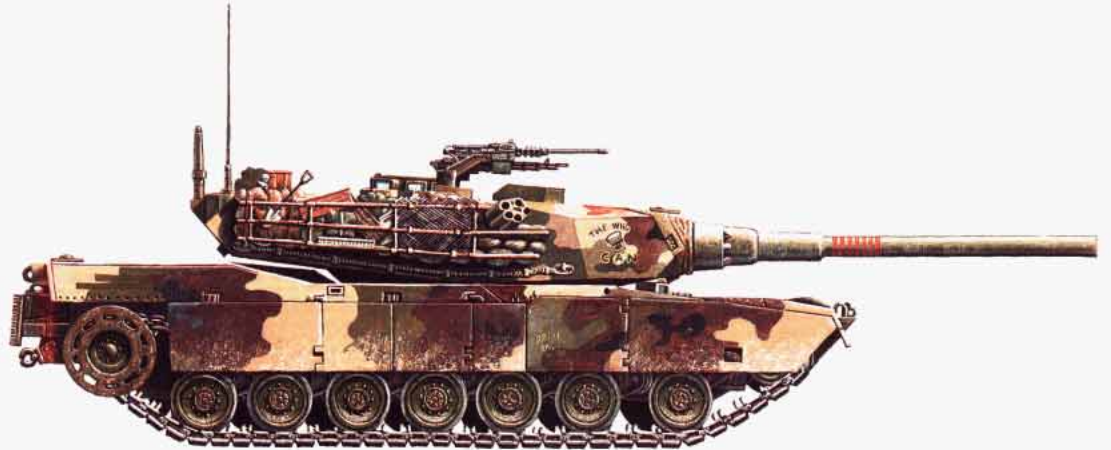

A2: M1A1 of 2nd Armored Division; Germany, summer 1998.

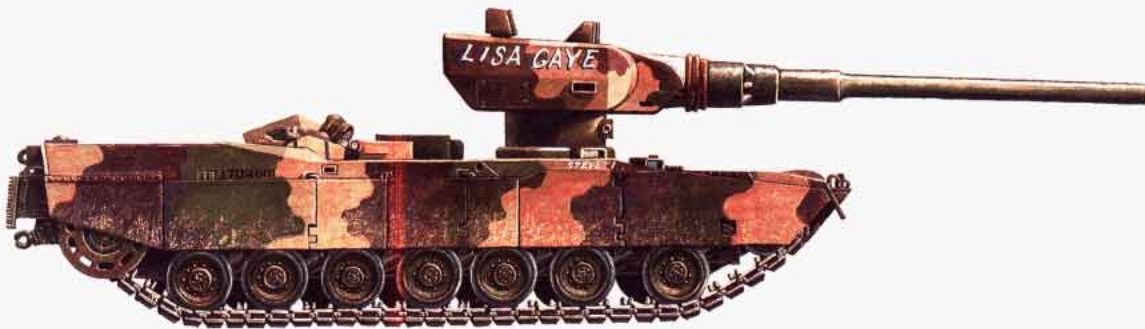

A3: M1A2, 3-70 Armor, 5th Infantry Division (Mechanized); Germany, fall, 1997(?).

A4: M691 Diana, 4-5 Air Defense Artillery, 1st Cavalry Division; Poland, spring 1997.

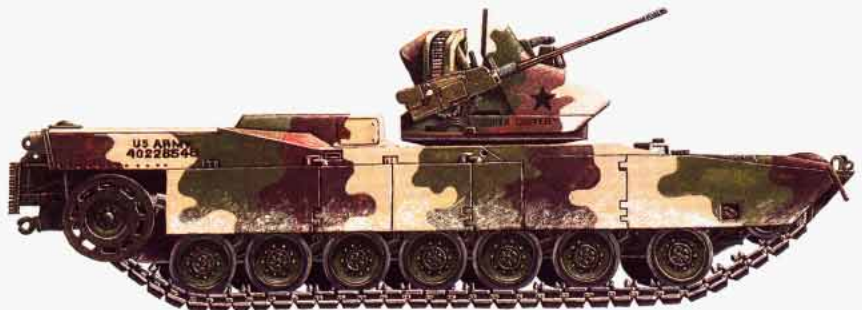

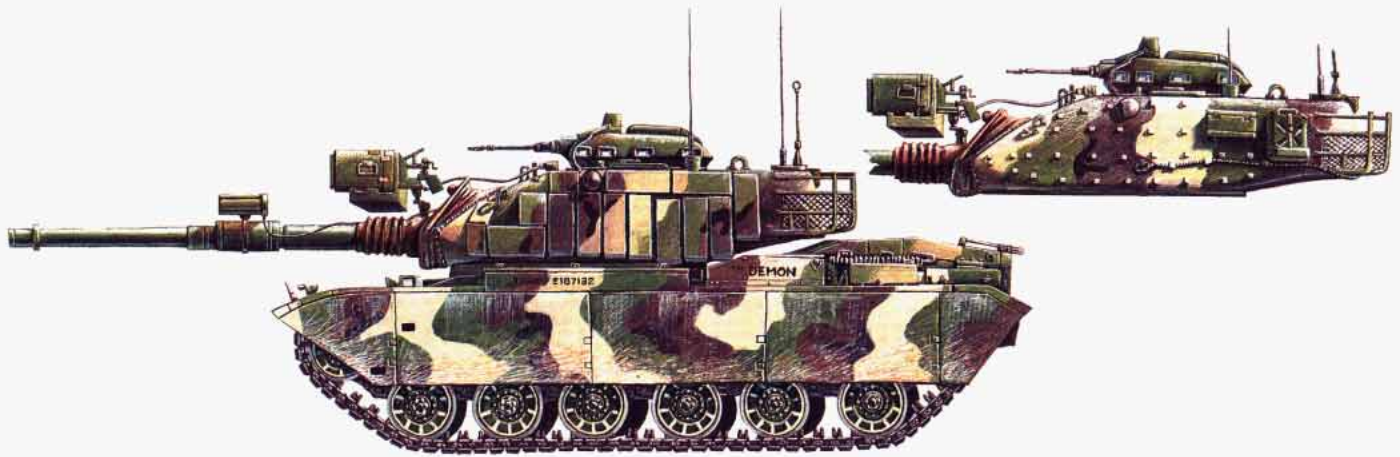

B1: M60A4, 1-127 Armor, 42nd Infantry Division (New York National Guard); Yugoslavia, spring, 1999.



B2: Cadillac Gage Stingray of 4-34 Armor, 8th Division (Mechanized); Poland, spring of 2000.



B3: LAV-75 of 2-60 Infantry, 9th Infantry Division (Motorized); Iran, spring of 1998.

B4: M17 LAVAA (Light Armored Vehicle, Anti Armor) of 11th Marine Artillery Regiment, 1st Marine Division; Iran, autumn of 1999.

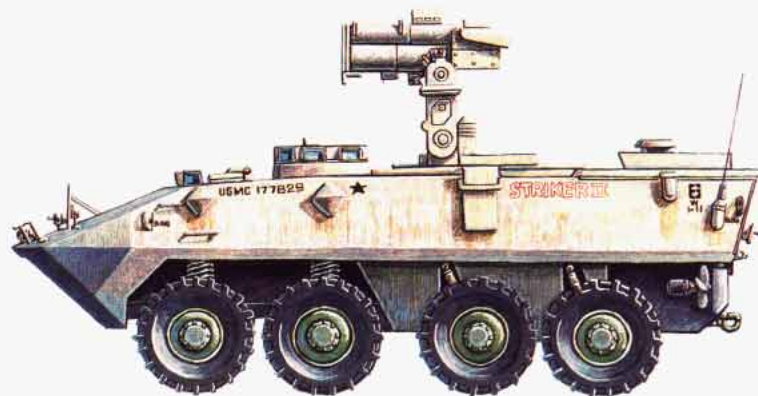



C1: M2 Bradley infantry fighting vehicle of Headquarters Company, 2nd Brigade, 24th Infantry Division (Mechanized); Iran, autumn, 1997.

C2: LAV-25 of E Troop, 44th Cavalry Squadron (Composite), 44th Armored Division; Bavaria, autumn 1999.



C3: LAV-PIVAD of 3-62 Air Defense Artillery, 10th Infantry Division (Mountain); British Columbia, summer of 1997.

C4: M113A3 armored personnel carrier of 2-136 Infantry (Minnesota National Guard), 36th Infantry Division (Mechanized); Germany, autumn of 1997.

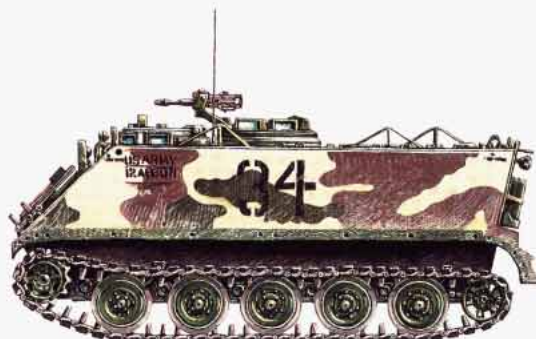

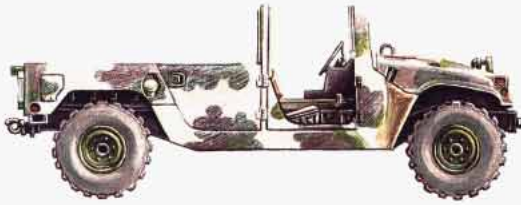

D1: HMMWV squad carrier of 9th Infantry Division (Motorized); Iran, autumn of 1998.



D2: HMMWV squad carrier of 3-47 Infantry, 9th Infantry Division (Motorized); Iran, autumn of 1998.

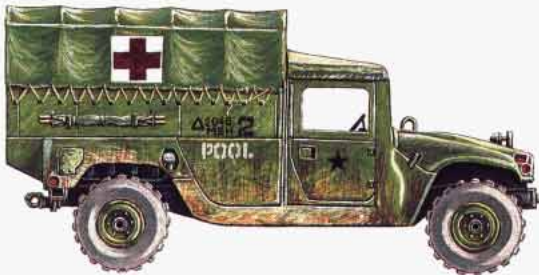

D3: HMMWV ambulance of the 2046th Mobile Surgical Hospital; Germany, summer of 1997.



D4: HMMWV TOW carrier of 2-2 Infantry, 9th Infantry Division (Motorized); Iran, autumn of 1998.



D5: HMMWV fire support vehicle of 2-23 Infantry, 9th Infantry Division (Motorized); Iran, autumn of 1998.



D6: 5/4-ton utility truck of 183rd Tactical Fighter Group (Reinforced); Al Qatif, Saudi Arabia, summer of 1998.



D7: Fast Attack Vehicle of the 9th Infantry Division (Motorized); Iran, autumn of 1998.



D8: Fast Attack Vehicle of 1-9 Infantry, 6th Infantry Division (Light); Germany, winter of 1999.



E1: M750 AC (Commando V-350) of 278th Armored Cavalry Regiment; Germany, spring 1998.



E2: Peacekeeper armored car of 278th Armored Cavalry Regiment; Germany, spring 1998.

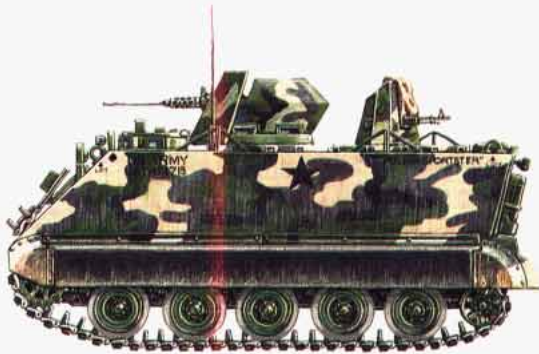

E3: M113A3 armored cavalry combat vehicle, 1-803 Armor (Washington National Guard); Poland, summer 1997.



E4: M115A1 armored cavalry combat vehicle of 163rd Armored Cavalry Regiment (Montana National Guard); Korea, 1998.

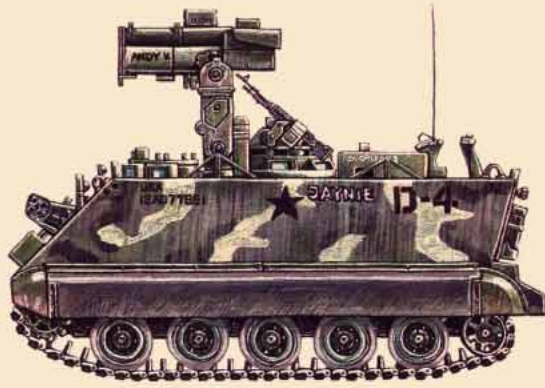

F1: M901 antiarmor vehicle of 256th Mechanized Brigade (Louisiana National Guard), 5th Infantry Division (Mechanized); Poland, summer of 2000.

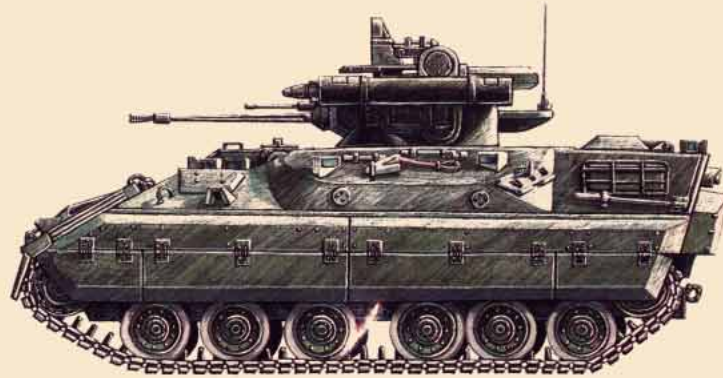

F2: M2A3 infantry fighting vehicle of 2nd Armored Division; Germany, spring of 1997.

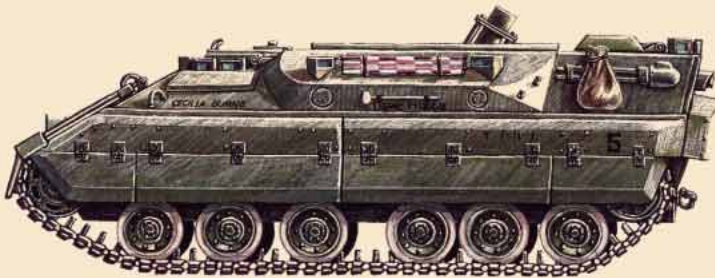

F3: M18 mortar carrier of 11th Marine Artillery Regiment, 1st Marine Division; Iran, summer 2000.

F4: M106 mortar carrier of 3-5 Marines, 1st Marine Division; Iran, summer of 2000.



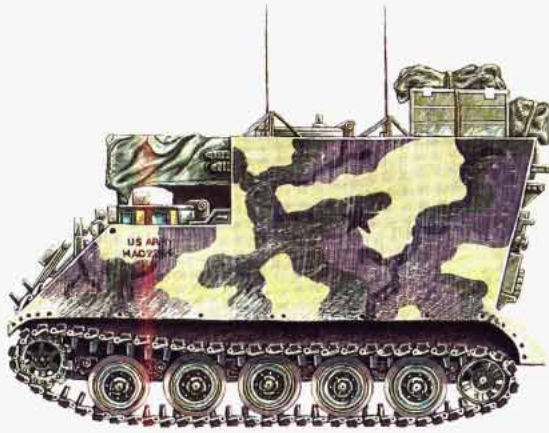

G1: M577A1 command post vehicle of 3-112 Armor, 49th Armored Division (Texas National Guard); Oklahoma, summer 1999.

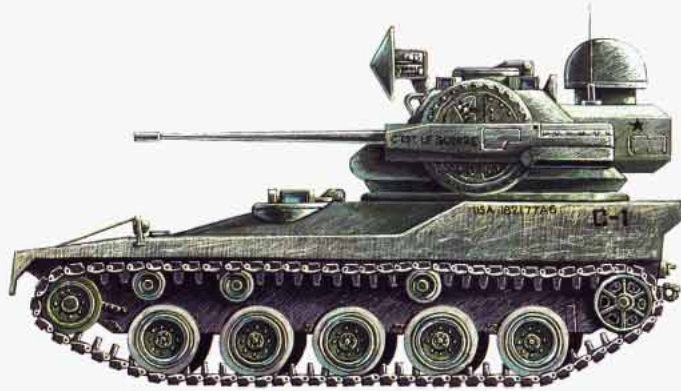

G2: M990 of 1-4 Air Defense Artillery, 9th Infantry Division (Motorized); Iran, spring of 1998.



G3: M728 combat engineer vehicle of 1-185 Armor (California National Guard), 40th Infantry Division (Mechanized); California, spring of 2000.

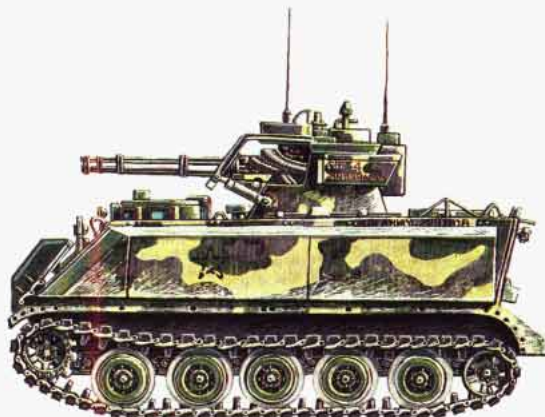

G4: M741A6 PIVAD of 5-62 Air Defense Artillery, The School Brigade; Oklahoma, summer of 1999.

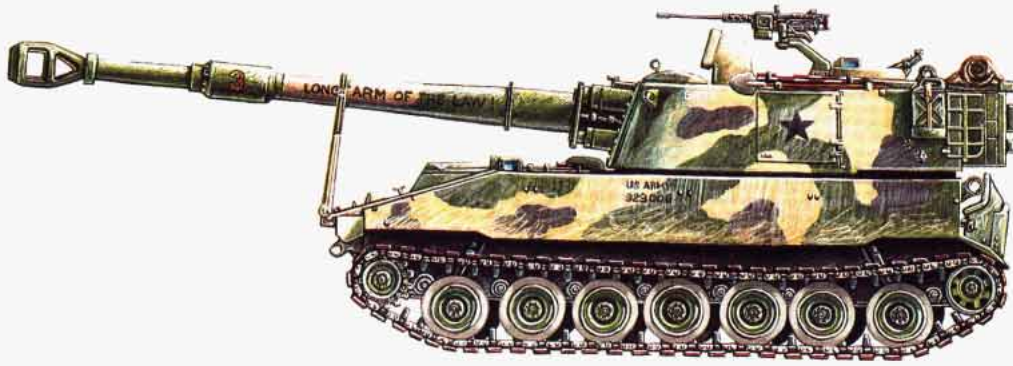

H1: M109A2 self-propelled howitzer of 3-41 Field Artillery, 3rd Infantry Division; Korea, autumn 1997.

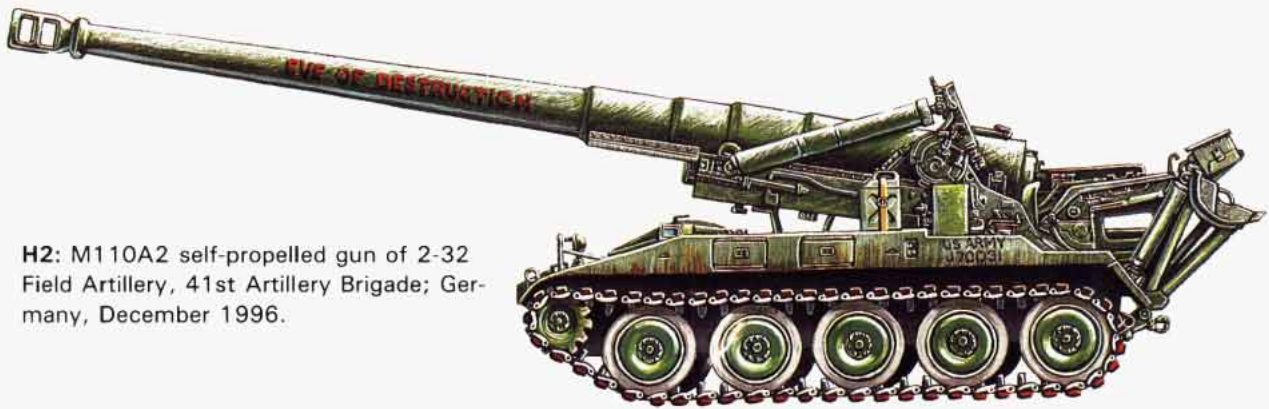

H2: M110A2 self-propelled gun of 2-32 Field Artillery, 41st Artillery Brigade; Germany, December 1996.

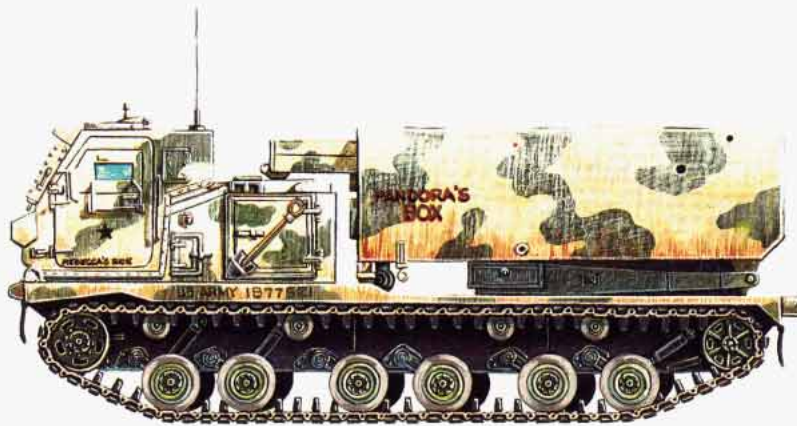

H3: M993 Multiple Launch Rocket System of Battery A, 13th Field Artillery Regiment, 24th Infantry Division (Mechanized); Iran, autumn 1998.

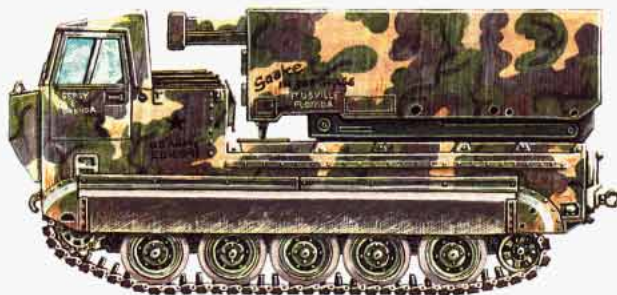

H4: M948 Light Artillery Rocket System (LARS) of Battery E, 11th Field Artillery Regiment, 6th Infantry Division (Light); Finland, July, 1997.

Equipment Descriptions

The following material supplements the **VEHICLES** section and other sections of the equipment list.

Unarmored Cargo Vehicles

HMMWV Squad Carrier: Per the description in the equipment list. *Price:* \$20,000 (C/S) *Armament:* M2HB MG (C) or Mark 19 AGL (C) *Ammo:* 175 × .50 BMG or 30 × 40mm grenades *Tr Move:* 200/60 *Com Move:* 70/25 *Fuel Cap:* 90 *Fuel Cons:* 30 *Fuel Type:* D, G, A *Load:* 1.25 tons *Veh Wt:* 2 tons *Crew:* 2 + 4 *Mnt:* 2

HMMWV Ambulance: An HMMWV variant for transport of wounded. *Price:* \$20,000 (C/S) *Tr Move:* 200/60 *Com Move:* 70/25 *Fuel Cap:* 90 *Fuel Cons:* 30 *Fuel Type:* D, G, A *Load:* 1.25 tons *Veh Wt:* 2 tons *Crew:* 2 + 6 ambulatory wounded or 4 stretcher cases *Mnt:* 2

HMMWV TOW Carrier: The standard Hummer fitted with a TOW launch system. *Price:* \$20,000 (C/S) *Armament:* TOW Launcher *Ammo:* 10 × TOW II *Tr Move:* 200/60 *Com Move:* 70/25 *Fuel Cap:* 90 *Fuel Cons:* 30 *Fuel Type:* D, G, A *Load:* 50 kg *Veh Wt:* 2 tons *Crew:* 3 *Mnt:* 4

HMMWV Fire Support Vehicle: The standard Hummer fitted with a 25mm chaingun turret. The weapon is fired by means of a downlinked television monitor connected to a console in the gunner's position (right front passenger compartment). *Price:* \$30,000 (C/S) *Armament:* 25mm Autocannon *Ammo:* 297 × 25mm *Tr Move:* 200/60 *Com Move:* 70/25 *Fuel Cap:* 90 *Fuel Cons:* 30 *Fuel Type:* D, G, A *Load:* 50 kg *Veh Wt:* 2 tons *Crew:* 3 *Mnt:* 6

Truck, cargo, 5/4-ton: The M880 series (M880-M885) and other medium-sized utility trucks are in common use. A pintle mount weapon is sometimes added to the cargo bed as a field modification. *Price:* \$15,000 (C/S) *Tr Move:* 180/35 *Com Move:* 60/20 *Fuel Cap:* 105 *Fuel Cons:* 20 *Fuel Type:* G, A *Load:* 1.75 tons *Veh Wt:* 2 tons *Crew:* 1 + 6 *Mnt:* 8

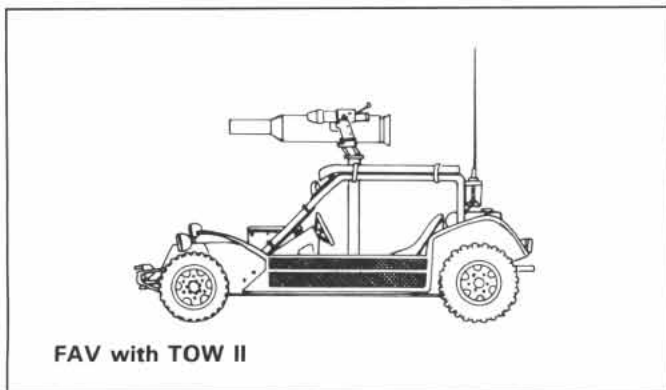

FAV (Fast Attack Vehicle): The FAV was developed in the 1980s as a scout and general tactical vehicle for the fast attack battalions of US army light divisions. The FAV resembles a dune buggy in configuration, and is fitted with an NHT weapons mount. It is usually armed with a machinegun (M2HB, MAG, or M60 MGs), a TOW launcher, or a Mark 19 GL. The vehicle is also provided with kevlar side and top armor sheets, attached to the roll bar framework. These sheets, intended to provide protection from shell fragments and small arms fire, were usually rolled up to avoid interference with crew visibility and to facilitate the crew's rapid departure from the vehicle in

stress situations. *Price:* \$15,000 (R/R) *Armament:* MAG MG *Ammo:* 561 × 7.62 N belted *Tr Move:* 220/70 *Com Move:* 75/30 *Fuel Cap:* 60 *Fuel Cons:* 20 *Fuel Type:* D, G, A *Load:* 80 kg *Veh Wt:* .75 tons *Crew:* 2 *Mnt:* 3

M648 10-ton Cargo Carrier: An unarmored cargo carrier on the same chassis as the M993 MLRS. Access to the forward located crew compartment is through two doors (one on each side) and a hatch located on the right top of the compartment. A tailgate in the rear facilitates loading/unloading of the open-topped cargo bed. *Price:* \$250,000 (S/R) *Armament:* M2HB MG (C) *Ammo:* 175 × .50 BMG *Tr Move:* 140/85 *Com Move:* 50/35 *Fuel Cap:* 650 *Fuel Cons:* 200 *Fuel Type:* D, A *Load:* 10 tons *Veh Wt:* 22 *Crew:* 1 *Mnt:* 4

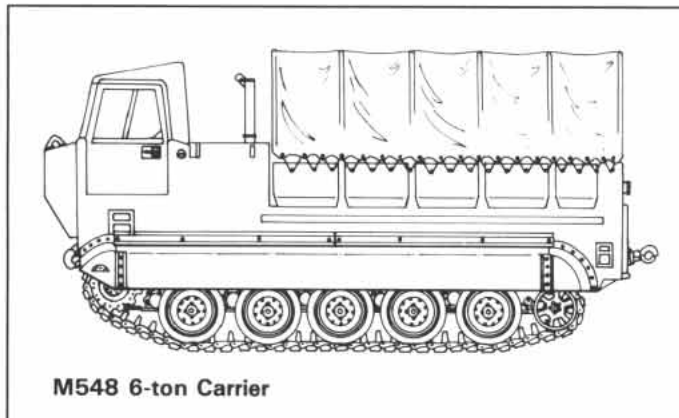

M548 6-ton Cargo Carrier: A cargo carrier variant of the workhorse M113 series chassis. It is nearly identical in layout to the M648 mentioned above, but smaller. *Price:* \$50,000 (C/S) *Armament:* M2HB MG (P) *Ammo:* 175 × .50 BMG *Tr Move:* 120/70 *Com Move:* 40/30 *Fuel Cap:* 380 *Fuel Cons:* 140 *Fuel Type:* D, A *Load:* 6 tons *Veh Wt:* 12 tons *Crew:* 2 *Mnt:* 5

Armored Personnel Carriers

M2 Bradley: Per the description in the equipment list. *Price:* \$200,000 (S/R) *RF:* +15 *Armament:* 25mm Autocannon, twin TOW launcher, MAG MG, 6 × M231 *Ammo:* 300 × 25mm, 7 × TOW II *Tr Move:* 140/85 *Com Move:* 50/35 *Fuel Cap:* 650 *Fuel Cons:* 200 *Fuel Type:* D, A *Load:* 1.5 tons *Veh Wt:* 20 tons *Crew:* 3 + 7 *Mnt:* 8

M2A3 Bradley II: An improved version of the Bradley APC. The main external differences are the smaller turret and the replacement of the TOW AT missiles with the superior Hellfire system. Otherwise, the vehicle is as described in the equipment list. *Price:* \$200,000 (S/R) *RF:* +15 *Armament:* 25mm Autocannon, twin Hellfire launcher, MAG MG, 6 × M231 *Ammo:* 300 × 25mm, 4 × Hellfire *Tr Move:* 140/85 *Com Move:* 50/35 *Fuel Cap:* 650 *Fuel Cons:* 200 *Fuel Type:* D, A *Load:* 1.5 tons *Veh Wt:* 20 tons *Crew:* 3 + 7 *Mnt:* 8

M3 Devers: An armored cavalry variant of the M2 Bradley. Externally, the vehicles are identical; internally, the M3 carries fewer passengers and more missiles. Characteristics are per the M2, except *Crew:* 3 + 3 and *Ammo:* 12 TOW II.

M113A3: A slightly modernized M113. Its description is per the equipment list, except for the addition of an armored cupola for the commander's hatch machinegun and paired gunshields for the cargo hatch weapons. *Price:* \$75,000 (S/R) *Armament:* M2HB MG, 2 × MAG MG (P) *Ammo:* 175 .50 BMG, 3300 × 7.62 N belted *Tr Move:* 120/70 *Com Move:* 40/30 *Fuel Cap:* 360 *Fuel Cons:* 120 *Fuel Type:* D, A *Load:* 2 tons *Veh Wt:*

11 tons Crew: 2+11 Mnt: 6

M113A3 ACCV: Per the M113 description in the equipment list. Price: \$75,000 (S/R) Armament: M2HB MG (C) Ammo: 175 x .50 BMG Tr Move: 120/70 Com Move: 40/30 Fuel Cap: 360 Fuel Cons: 120 Fuel Type: D, A Load: 2 tons Veh Wt: 11 tons Crew: 2+11 Mnt: 6

M115A1 ACCV: An improved version of the M113 ACCV, armed with a 25mm chaingun turret, eliminating the cargo deck weapons mounts. It is otherwise identical to the M113 from the equipment list. Price: \$75,000 (S/R) Armament: 25mm Autocannon Ammo: 297 25mm Tr Move: 120/70 Com Move: 40/30 Fuel Cap: 360 Fuel Cons: 120 Fuel Type: D, A Load: 1 ton Veh Wt: 12 tons Crew: 3+6 Mnt: 6

AAVP9: The AAVP9 is an advanced version of the AAVP7A1 amphibious armored personnel carrier, entering service in the early 1990's. A 40mm AGL and M2HB MG combination is mounted in a small cupola on the right front hull deck, and there are two smaller hatches for the driver and vehicle commander on the left front hull deck. The rear deck contains two large doors for disembarking personnel, and the rear has a ramp/door which can be lowered as well. The vehicle is fully amphibious. The 40mm AGL is identical in performance and characteristics to the Mark 19. Price: \$80,000 (R/R) RF +15 Armament: 40mm AGL, M2HB MG Ammo: 350 x 40mm Tr Move: 120/70 Com Move: 40/30 Fuel Cap: 360 Fuel Cons: 120 Fuel Type: D, A Load: 4 tons Veh Wt: 18 tons Crew: 2+22 Mnt: 6

Light Combat Vehicles

LAV-25: Per the description in the equipment list. Price: \$100,000 (S/R) RF: +15 Armament: 25mm Autocannon, MAG MG Ammo: 297 x 25mm Tr Move: 180/70 Com Move: 60/25 Fuel Cap: 290 Fuel Cons: 70 Fuel Type: D, A Load: 2 tons Veh Wt: 12 tons Crew: 3+8 Mnt: 6

LAV-75: Per the description in the equipment list. Price: \$250,000 (R/R) RF: +40 Armament: 75mm Autocannon, MAG MG Ammo: 36 x 75mm Tr Move: 160/95 Com Move: 55/40 Fuel Cap: 520 Fuel Cons: 130 Fuel Type: D, G, AvG, A Load: .5 ton Veh Wt: 15 tons Crew: 3 Mnt: 10

M750 AC (Commando V-350): Unlike the other Cadillac Gage armored vehicles, the V-350 was type-standardized by the US Army, entering service in the mid 1990's. The M750 is a larger version of CG's V-series of armored cars (beginning with the Vietnam-era M706 Commando V-100). Several versions were built by CG, but the AC variant (also used by MP and airfield security units) was the only one ever officially adopted. A six-wheeled armored car (that is, 6x6, unlike the previous 4x4 versions of the V-series), the M750 has a driver's and a commander's hatch on the front deck, a gunner's hatch on the turret, and another hatch on the rear deck, fitted with a pintle weapons mount. A two-part hatch is located on the rear. Price: \$50,000 (S/R) Armament: 2 x MAG MG, M2HB (P) Ammo: 1122 7.62 N belted, 175 .50 BMG Tr Move: 160/95 Com Move: 55/40 Fuel Cap: 480 Fuel Cons: 80 Fuel Type: D, A Load: 1 ton Veh Wt: 13 Crew: 4 Mnt: 6

Peacekeeper Armored Car: A Cadillac Gage 4 x 4 light armored car, acquired by the USAF in 1985 for airfield security duties and by the Department of Energy for perimeter security at certain nuclear reactor facilities. It contains two conventional automobile-type doors (one right, one left) for the driver and front passenger, plus two cargo doors in the rear. On the top center of the cargo/passenger compartment there is a 360° gunshield/mount for the vehicle's normal armament of twin MAG MGs. A searchlight is usually fitted to this gunshield on perimeter security models. Price: \$35,000 (S/R) Armament: 2 x MAG MG Ammo: 1122 x 7.62 N Belted Tr Move: 200/60 Com Move: 70/25 Fuel Cap: 280 Fuel Cons: 40 Fuel Type: G, A Load: 500 kg Veh Wt: 5 tons Crew: 3+3 Mnt: 4

M577A1 CP: The command post variant of the M113 APC. The main modifications are the expansion of the passenger compartment to permit its occupants to stand and the installation of an air-conditioner (to protect fragile electronic equipment from over-heating, not for crew comfort). The commanders hatch is shifted forward on the deck, and the cargo door on the deck is eliminated. This vehicle also contains an integral 7.5 kw generator and a large tent which can be erected at the rear of the vehicle to expand the area available in the command center. Price: \$90,000 (S/R) Armament: M2HB MG (C) Ammo: 175 x .50 BMG Tr Move: 120/70 Com Move: 40/30 Fuel Cap: 360 Fuel Cons: 120 Fuel Type: D, A Load: 500 kg Veh Wt: 11 tons Crew: 2+6 Mnt: 6

M18 Mortar Carrier: The M18 is the mortar variant of the Bradley AFV. The turret has been removed (a hatch and MG mount take its place), and the interior heavily modified to take the M121 120mm mortar and its associated equipment. Price: \$200,000 (S/R) Armament: M121 120mm mortar, MAG MG Ammo: 40 x 120mm mortar Tr Move: 140/85 Com Move: 50/35 Fuel Cap: 650 Fuel Cons: 200 Fuel Type: D, A Load: 1.5 tons Veh Wt: 20 tons Crew: 3 Mnt: 8

M106 Mortar Carrier: An M113, heavily modified to carry the M30 107mm (4.2'') mortar. Most of the vehicle's main deck has been removed, but the commander's MG mount remains intact. Price: \$75,000 (S/R) Armament: M30 107mm (4.2'') Mortar, M2HB MG (P) Ammo: 24 x 107mm (4.2'') mortar Tr Move: 120/70 Com Move: 40/30 Fuel Cap: 360 Fuel Cons: 120 Fuel Type: D, A Load: 200 kg Veh Wt: 12 tons Crew: 6 Mnt: 6

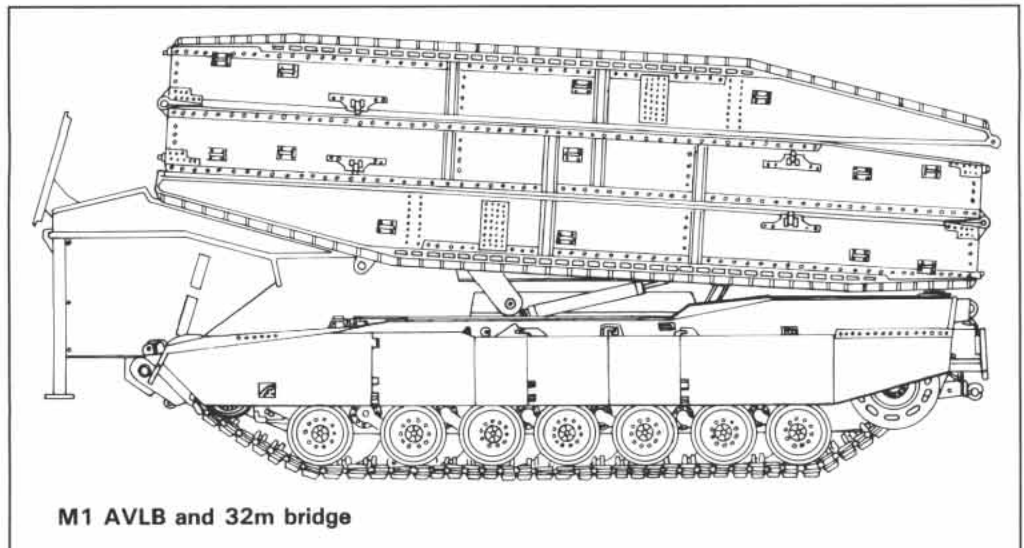

M1 AVLB and 32m bridge

Engineer Vehicles

M728 CEV: The M728 CEV (combat engineer vehicle) is a variant of the M60 tank. The vehicle's main gun has been replaced with a 165mm demolition gun, and a crane has been installed on the turret (which also lacks reactive armor plates and the studs to hold them). Aside from these differences, and the lack of side skirts, its characteristics are identical to the M60A4. *Price:* 600,000 (R/R) *Armament:* 165mm gun, MAG MG, M2HB MG (C) *Ammo:* 30 × 165mm HEP-T *Tr Move:* 100/80 *Com Move:* 50/30 *Fuel Cap:* 985 *Fuel Cons:* 240 *Fuel Type:* D, A *Load:* 700 kg *Veh Wt:* 57 tons *Crew:* 4 *Mnt:* 14

M1 AVLB (Armored Vehicle Launched Bridge): A 32m span folding bridge deployed from a modified M1 chassis. The tank's turret and main gun have been removed and the deployment machinery substituted. The MG is usually deployed only after the bridge has been emplaced. This bridge may be used on either the M1 or M60 AVLB chassis. *Price:* \$200,000 (R/R) *Armament:* M2HB MG (C) *Ammo:* 175 .50 BMG *Tr Move:* 110/90 *Com Move:* 30/20 *Fuel Cap:* 1800 *Fuel Cons:* 600 *Fuel Type:* D, G, AvG, A *Load:* 200 kgs *Veh Wt:* 33 tons (+ Bridge 14 tons) *Crew:* 2 *Mnt:* 14

M60 AVLB: A 17m span scissors-type folding bridge deployed from a modified M60 chassis. The tank's turret and main gun have been removed and the deployment machinery substituted. The MG is usually deployed only after the bridge has been emplaced. This bridge may be used on either the M1 or M60 AVLB chassis. *Price:* \$175,000 (R/R) *Armament:* M2HB MG (C) *Ammo:* 175 .50 BMG *Tr Move:* 80/60 *Com Move:* 35/25 *Fuel Cap:* 800 *Fuel Cons:* 240 *Fuel Type:* D, A *Load:* 100 kgs *Veh Wt:* 37 tons (+ Bridge 12 tons) *Crew:* 2 *Mnt:* 14

Main Battle Tanks

M1 Abrams: Per the description in the equipment list. *Price:* \$600,000 (R/R) *RF:* +40 *Armament:* 105mm gun, MAG MG, M2HB MG (C) *Ammo:* 55 × 105mm *Tr Move:* 140/110 *Com Move:* 50/40 *Fuel Cap:* 1920 *Fuel Cons:* 560 *Fuel Type:* D, G, AvG, A *Load:* 700 kg *Veh Wt:* 54 tons *Crew:* 4 *Mnt:* 14

M1A1 Abrams II: Per the description in the equipment list. *Price:* \$650,000 (R/R) *RF:* +40 *Armament:* 120mm gun, MAG MG, M2HB MG (C) *Ammo:* 40 × 120mm *Tr Move:* 140/110 *Com Move:* 45/35 *Fuel Cap:* 1920 *Fuel Cons:* 560 *Fuel Type:* D, G, AvG, A *Load:* 700 kg *Veh Wt:* 55 tons *Crew:* 4 *Mnt:* 14

M1A2 Abrams III (Giraffe): Per the description in the equipment list. *Price:* \$700,000 (R/R) *RF:* +40 *Armament:* 120mm gun, MAG MG, M2HB MG (C) *Ammo:* 40 × 120mm *Tr Move:* 130/100 *Com Move:* 50/40 *Fuel Cap:* 1920 *Fuel Cons:* 560 *Fuel Type:* D, G, AvG, A *Load:* 700 kg *Veh Wt:* 55 tons *Crew:* 3 *Mnt:* 14

M60A4: Developed in the 1950's as an outgrowth of the M48 series of AFVs, the M60 series (the M60, M60A1, M60A2, and M60A3) was the mainstay of US armored forces from its adoption in 1962 until it began to be replaced by the M1 Abrams family in the 1980's. In 1987 the M60A4 was adopted as type standard for all remaining M60 models in inventory, and work

began on bringing the earlier models up to A4 standards. Side skirts for the tracks and "Blazer" reactive armor (see page 34) for the turret are the primary features distinguishing the M60A4 from earlier versions. There is a single driver's hatch on the forward deck. The turret mounts a commander's cupola containing an M2HB MG and a loader's hatch, both on the turret deck (the cupola is fitted with a hatch as well). *Price:* \$400,000 (S/R) *RF:* +40 *Armament:* 105mm gun, MAG MG, M2HB MG (C) *Ammo:* 57 × 105mm *Tr Move:* 100/80 *Com Move:* 50/30 *Fuel Cap:* 900 *Fuel Cons:* 210 *Fuel Type:* D, A *Load:* 700 kg *Veh Wt:* 53 tons *Crew:* 4 *Mnt:* 14

Cadillac Gage Stingray: The Stingray was a private venture tank developed by Cadillac Gage in the US and Royal Ordnance of England, designed for the export weapons market. Although never adopted by the US Army, the Stingray was a less expensive AFV alternative in many armies in the years prior to the war. In 1997, conditions in the US were such that Stingray inventories and production were requisitioned and the vehicles assigned as replacement equipment to several units in the US and abroad. The Stingray's layout is conventional: there is a driver's hatch on the forward hull deck, and a commander's hatch on the turret deck with a weapons mount. The 105mm turret on the Stingray can also be fitted into the various other CG Commando chassis (M706, M750), and a small number of such "Stingray Juniors" were produced. *Price:* \$800,000 (R/R) *RF:* +40 *Armament:* 105mm gun, MAG MG, M2HB MG(C) *Ammo:* 36 × 105mm *Tr Move:* 140/110 *Com Move:* 50/40 *Fuel Cap:* 1920 *Fuel Cons:* 560 *Fuel Type:* D, G, AvG, A *Load:* 700 kg *Veh Wt:* 21 tons *Crew:* 4 *Mnt:* 14

Self-Propelled Artillery

M691 Diana: The M691 Diana is one of a number of air defense systems adopted by the US army after the cancellation of M988 DIVAD system production in the mid-1980's. The Diana mounts a fully rotating turret with twin 25mm Oerlikon autocannons on an M1 Abrams tank chassis. *Price:* \$700,000 (R/R) *RF:* +15 *Armament:* 2 × Oerlikon 25mm KBB Autocannons *Ammo:* 500 25mm *Tr Move:* 140/110 *Com Move:* 50/40 *Fuel Cap:* 1920 *Fuel Cons:* 560 *Fuel Type:* D, G, AvG, A *Load:* 700 kg *Veh Wt:* 44 tons *Crew:* 3 *Mnt:* 14

M17 LAVAA: An antiarmor variant of the LAV-25, achieved by replacing the 25mm chaingun turret with a TOW launch system. The launcher can be extended upwards, to permit the

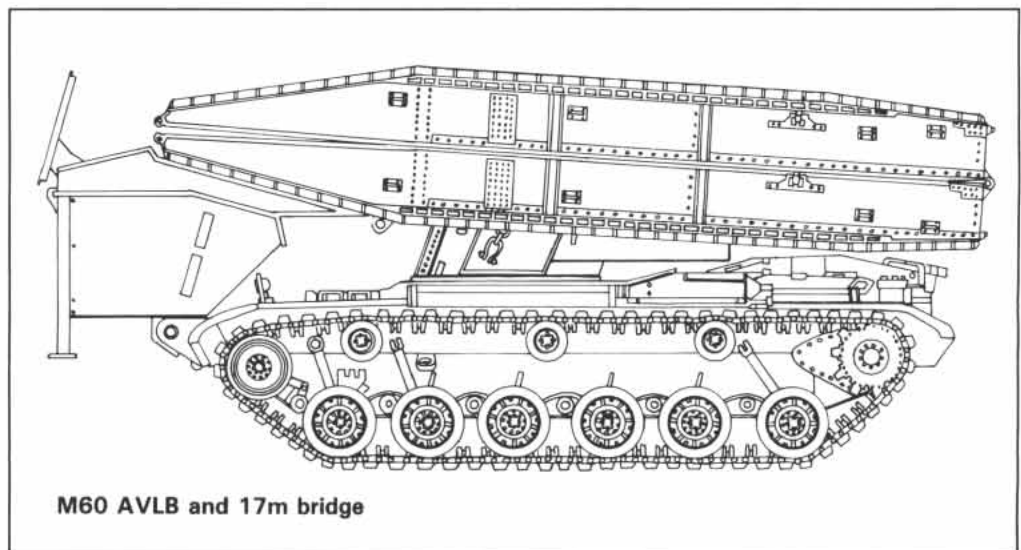

M60 AVLB and 17m bridge

weapon to be aimed and fired while the vehicle is hull down, for improved survivability. It is otherwise externally identical to the LAV-25. *Price*: \$100,000 (R/R) *RF*: +15 *Armament*: TOW launcher, MAG MG *Ammo*: 10×TOW II missiles *Tr Move*: 180/70 *Com Move*: 60/25 *Fuel Cap*: 290 *Fuel Cons*: 70 *Fuel Type*: D, A *Load*: 400 kg *Veh Wt*: 12 tons *Crew*: 3 *Mnt*: 6

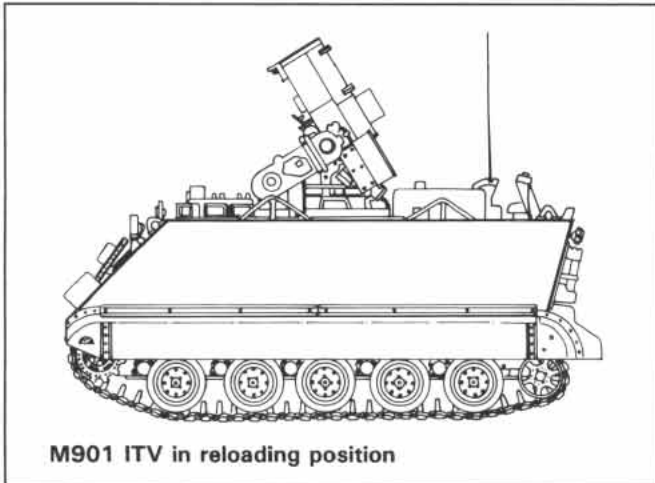

M901 ITV in reloading position

M901 ITV: Yet another variant of the M113 chassis, the ITV (improved TOW Vehicle) was designed to replace earlier TOW carriers (hence the name). The TOW launcher replaces the commander's hatch, and automatic reloading machinery largely fills the rear crew compartment. Otherwise the vehicle is as the M113 in the equipment list. *Price*: \$75,000 (S/R) *RF*: +15 *Armament*: TOW Launcher (twin) *Ammo*: 10 TOW II missiles *Tr Move*: 120/70 *Com Move*: 40/30 *Fuel Cap*: 360 *Fuel Cons*: 120 *Fuel Type*: D, A *Load*: 700 kg *Veh Wt*: 11 tons *Crew*: 3 *Mnt*: 6

LAV-PIVAD: Another LAV-25 variant, fitted with a PIVAD (Product Improved Vulcan Air Defense) system. The LAV-PIVAD was designed to provide a light-weight, mobile air defense weapon for use in army light divisions. Aside from the weapon, it is nearly identical to the LAV-25. *Price*: \$100,000 (S/R) *RF*: +15 *Armament*: Vulcan 20mm ADA Autocannon, MAG MG *Ammo*: 1800×20mm *Tr Move*: 180/70 *Com Move*: 60/25 *Fuel Cap*: 290 *Fuel Cons*: 70 *Fuel Type*: D, A *Load*: 400 kg *Veh Wt*: 12 tons *Crew*: 3 *Mnt*: 6

M990 ADA: A LAV-75 chassis fitted with a twin 30mm Bofors anti-aircraft turret, incorporating an improved DIVAD fire-control and target acquisition system. It is otherwise identical to the LAV-75 in the equipment list. *Price*: \$250,000 (R/R) *RF*: +15 *Armament*: 2×30mm Bofors Autocannon, MAG MG *Ammo*: 500×30mm *Tr Move*: 160/95 *Com Move*: 55/40 *Fuel Cap*: 520 *Fuel Cons*: 130 *Fuel Type*: D, G, AvG, A *Load*: .5 ton *Veh Wt*: 15 tons *Crew*: 3 *Mnt*: 10

M741A6 PIVAD: Another anti-aircraft weapon, an M113 fitted with a PIVAD system. Aside from the weapon, which replaces the commander's hatch, it is nearly identical to the M113 APC in the equipment list. *Price*: \$75,000 (R/R) *Armament*: Vulcan 20mm ADA Autocannon *Ammo*: 1800×20mm *Tr Move*: 120/70 *Com Move*: 40/30 *Fuel Cap*: 360 *Fuel Cons*: 120 *Fuel Type*: D, A *Load*: 20 kg *Veh Wt*: 11 tons *Crew*: 3 *Mnt*: 8

M109A2 SP: Per the description in the equipment list. *Price*: \$300,000 (R/R) *RF*: +15 *Armament*: 155mm howitzer, M2HB MG (C) *Ammo*: 36×155mm *Tr Move*: 110/65 *Com Move*: 35/25 *Fuel Cap*: 450 *Fuel Cons*: 150 *Fuel Type*: D, A *Load*: 1 ton *Veh Wt*: 25 tons *Crew*:

6 *Mnt*: 10

M110A2 SP: A self-propelled artillery system on a heavy chassis developed for the army by the Pacific Car and Foundry Company. The gun system is mounted externally on the chassis, and (unlike the M109) there is no protection for the gun crew (except for the driver, who rides inside) or for the ammunition. To remedy this (at least for the crew), a kit consisting of a tubular metal framework and kevlar shields was issued, but most crews found them too cumbersome to erect. They were usually discarded or left with the supply units. *Price*: \$375,000 (R/R) *Armament*: 203mm howitzer *Ammo*: 2×203mm (including propelling charges) *Tr Move*: 95/50 *Com Move*: 30/20 *Fuel Cap*: 704 *Fuel Cons*: 180 *Fuel Type*: D, A *Load*: 2 tons *Veh Wt*: 31 tons *Crew*: 6 *Mnt*: 10

M993 MLRS: The M993 was the first multiple rocket launcher System deployed in significant numbers by the US army since WWII. The vehicle uses a chassis developed by FMC and a large, boxlike rack of twelve launching tubes (which can be rotated 360°), behind a forward-mounted crew compartment. The tubes can be discharged in pairs, or ripple-fired. Access to the forward located crew compartment is through two doors (one on each side) and a hatch located on the right top of the compartment. The weapon can be reloaded by one person, using an integral derrick to hoist the ammo pods (6 rockets each) onto the vehicle. *Price*: \$250,000 (S/R) *Armament*: 227mm MRL, M2HB MG (P) *Ammo*: 12×227mm rockets *Tr Move*: 140/85 *Com Move*: 50/35 *Fuel Cap*: 650 *Fuel Cons*: 200 *Fuel Type*: D, A *Load*: 300 kgs *Veh Wt*: 22 *Crew*: 3 *Mnt*: 6

M948 LARS: Built on the M548 cargo carrier chassis, and using 160mm rockets instead of 227mm ones, the M948 Light Artillery Rocket System is smaller than the M993 MLRS, but identical in layout. *Price*: \$225,000 (S/R) *Armament*: 160mm MRL, M2HB MG (C) *Ammo*: 12×160mm rockets *Tr Move*: 120/70 *Com Move*: 40/30 *Fuel Cap*: 360 *Fuel Cons*: 120 *Fuel Type*: D, A *Load*: 150 kgs *Veh Wt*: 18 tons *Crew*: 3 *Mnt*: 6

M917 ADATS (Air Defense Antitank System): A quadruple ADATS missile launching system fitted to the LAV-75 chassis. This vehicle is an attempt to combine antiarmor and anti-aircraft capabilities in a single vehicle. *Price*: \$225,000 (R/R) *RF*: +15 *Armament*: Two Quad ADATS missile launchers (8 tubes total), MAG MG *Ammo*: 16 missiles (8 in the tubes) *Tr Move*: 160/95 *Com Move*: 55/40 *Fuel Cap*: 520 *Fuel Cons*: 130 *Fuel Type*: D, G, AvG, A *Load*: 200 kgs *Veh Wt*: 15 tons *Crew*: 3 *Mnt*: 11

M920 M2 Hellfire AT Vehicle: The M2 Bradley chassis with the turret removed and a quadruple Hellfire antiarmor missile launcher fitted into its place. *Price*: \$200,000 (S/R) *RF*: +15 *Armament*: Quadruple Hellfire launcher, MAG MG *Ammo*: 8×Hellfire missiles *Tr Move*: 140/85 *Com Move*: 50/35 *Fuel*

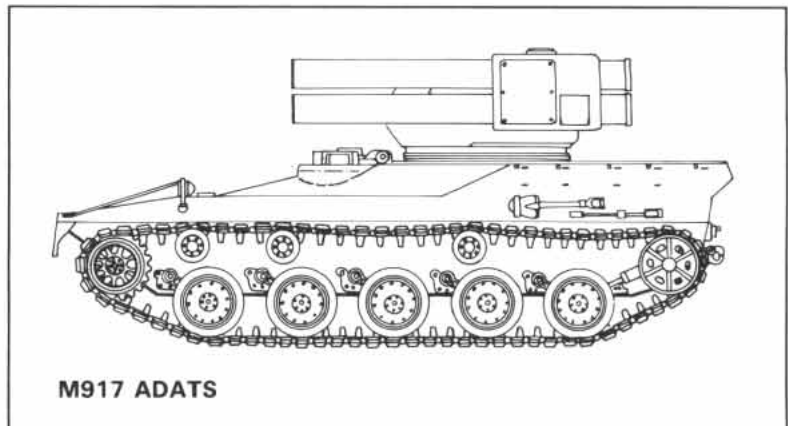

M917 ADATS

Cap: 650 Fuel Cons: 200 Fuel Type: D, A Load: 200 kgs Veh Wt: 20 tons Crew: 3+7 Mnt: 8

M757 Blazer: The Blazer is the basic M2 Bradley chassis fitted out for an anti-aircraft role with a triple-barreled 30mm chaingun system and a quadruple stinger launcher. Price: \$200,000 (R/R) RF: +15 Armament: 20mm PIVAD, quad stinger launcher, MAG MG Ammo: 1800 20mm, 12 stinger missiles Tr Move: 140/85 Com Move: 50/35 Fuel Cap: 650 Fuel Cons: 200 Fuel Type: D, A Load: 200 kgs Veh Wt: 21 tons Crew: 4 Mnt: 9

MPGS-90: A LAV-25 chassis mounting a reduced pressure 90mm gun similar to the British 90mm Cockerill. Price: \$250,000 (R/R) RF: +15 Armament: 90mm gun, MAG MG Ammo: 24 x 90mm gun Tr Move: 180/70 Com Move: 60/25 Fuel Cap: 290 Fuel Cons: 70 Fuel Type: D, A Load: 500 kgs Veh Wt: 13 tons Crew: 4 Mnt: 8

M48 Chaparral: The M48 Chaparral air defense artillery vehicle consists of a modified M548 chassis (designated M730) and an M54 missile launch system. Price: \$150,000 (S/R) RF: +15 Armament: Quad Chaparral missiles Ammo: 12 Chaparral missiles Tr Move: 120/70 Com Move: 40/30 Fuel Cap: 380 Fuel Cons: 140 Fuel Type: D, A Load: 100 kgs Veh Wt: 13 tons Crew: 6 Mnt: 8

M975A3 Roland II: The Franco-German Roland anti-aircraft missile system was manufactured in America under license, beginning in the 80's. The US version consisted of the Roland turret (incorporating the target acquisition and tracking electronics) fitted to a modified M109 chassis. The twin launcher is reloaded from an autoloader in the rear of the vehicle's hull. Price: \$300,000 (R/R) RF: +15 Armament: Twin Roland missile launchers Ammo: 12 Roland missiles Tr Move: 110/65 Com Move: 35/25 Fuel Cap: 450 Fuel Cons: 150 Fuel Type: D, A Load: 200 kg Veh Wt: 26 tons Crew: 4 Mnt: 8

FIREARMS

Howitzers

M202 105mm How (towed): A lightweight 105mm howitzer, requiring 8 crew. It may be towed by any vehicle over 2 tons in size. Wt: 2 tons Price: \$50,000 (S/R)

155mm How: A large caliber howitzer which may be mounted on the M109A2 or on a towed carriage (M198). In the towed version, it requires a crew of 11. It may be towed by any vehicle over 5 tons in size. Wt: 6.8 tons Price: \$75,000 (S/R)

Multiple Rocket Launchers

160mm LARS: A 12-barreled rocket launcher system, mounted on the M948.

227mm MRLS: A 12-barreled rocket launcher system, mounted on the M993.

Antiarmor Missile Launchers

Hellfire launcher: A quadruple missile launcher, mounted on the Blazer antiarmor vehicle.

Anti-aircraft Missiles

M54 Chaparral launcher: A quadruple missile launcher, mounted on the M730 chassis to form the M48 Chaparral anti-aircraft vehicle.

Roland II launcher: A twin missile launcher, used in

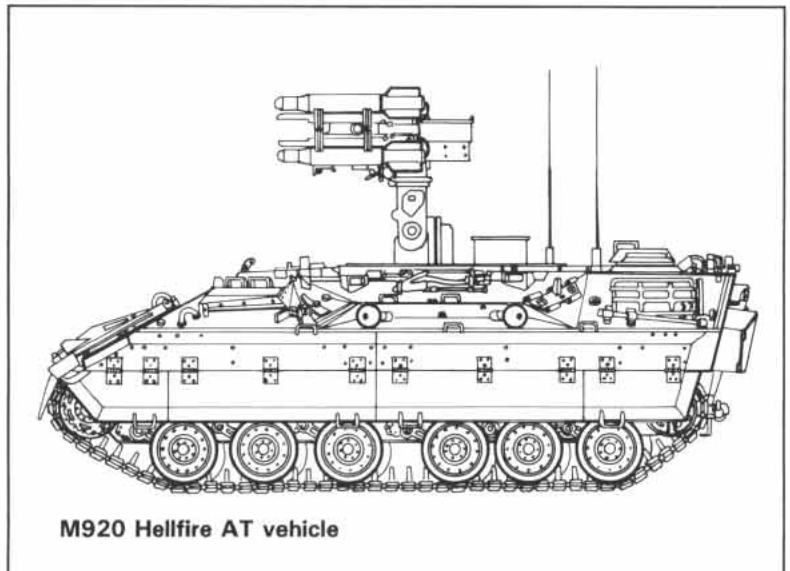

M920 Hellfire AT vehicle

the M975A3 Roland II anti-aircraft vehicle.

Stinger launcher: A quadruple missile launcher, mounted on the M757 Blazer ADA vehicle.

ADATS launcher: A quadruple missile launcher, mounted on the M917 ADATS antiarmor/anti-aircraft vehicle.

Large Caliber Guns

20mm PIVAD: A six-barreled gatling gun, fed by an 1800 round drum in the vehicle mounted version, or by 100 round belts in the towed version. The towed PIVAD may be pulled by any vehicle 2 tons or more in size. Wt: (towed) 1.8 tons Price: \$75,000 (R/R).

25mm Oerlikon Autocannon: A large caliber anti-aircraft autocannon, used in a twin mount on the M691 Diana ADA. Ammunition is fed continuously from an internal drum magazine to each weapon.

30mm Bofors Autocannon: A large caliber anti-aircraft autocannon, used in a twin mount on the M990 ADA. Ammunition is fed continuously from an internal drum magazine to each weapon.

90mm gun: A large caliber low pressure 90mm gun mounted in the MPGS vehicle.

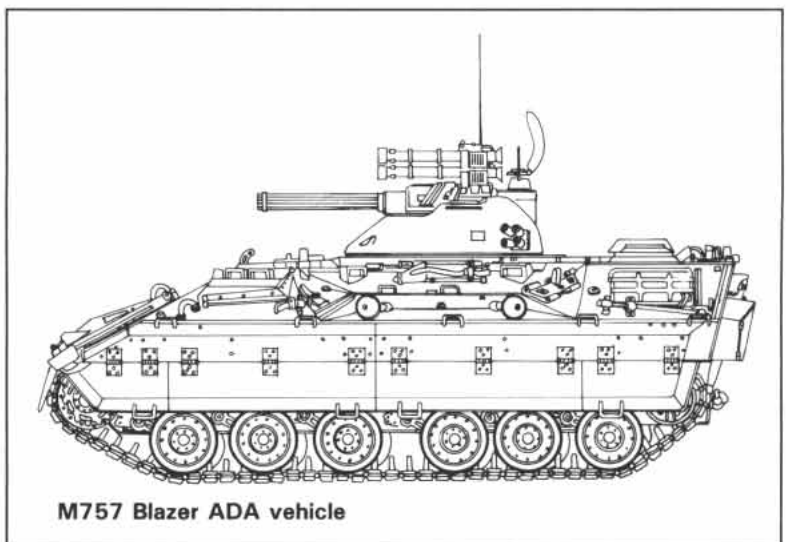

M757 Blazer ADA vehicle

165mm demolition gun: A short barreled gun mounted on the M728 CEV, intended for destruction of concrete bunkers and other fortifications, as well as roadblocks, buildings, and other constructions.

Howitzers

105mm How: A large caliber howitzer on a towed mount (M202). It does not use the same ammunition as the 105mm gun.

155mm Howitzer: A large caliber howitzer on a towed mount (M198) or on the M109A2.

M201 203mm (8'') howitzer: A large caliber howitzer mounted on the M110A2.

Ammunition

Rockets

160mm Rocket HE: Wt:700 kg per case of 6 rounds, Price: \$2500 per case (R/R).

160mm Rocket ICM: Wt:700 kg per case of 6 rounds, Price: \$2500 per case (R/R).

160mm Rocket CHEM: Wt:700 kg per case of 6 rounds, Price: \$2500 per case (R/R).

227mm Rocket HE: Wt:1000 kg per case of 6 rounds, Price: \$3000 per case (R/R).

227mm Rocket ICM: Wt:1000 kg per case of 6 rounds, Price: \$3000 per case (R/R).

227mm Rocket ILLUM: Wt:1000 kg per case of 6 rounds, Price: \$3000 per case (R/R).

227mm Rocket CHEM: Wt:1000 kg per case of 6 rounds, Price: \$3000 per case (R/R).

Antiarmor Missiles

Hellfire: A laser-homing antiarmor missile with a HEAT warhead Wt:35 kg, Price: \$2000 (S/R).

ADATS: A combination antiarmor/antiaircraft missile. Wt: 45 kg Price: \$2500 (R/R).

Antiaircraft Missiles

Chaparral (AGM87A): A heat-seeking antiaircraft missile with an HE warhead. Wt: 90 kg, Price: \$1,500 (S/R).

Roland II: A radar guided antiaircraft missile with an HE warhead. Wt: 80 kg, Price: \$2500 (R/R).

ADATS: See ADATS entry, above.

FIM92B Stinger: A heatseeking antiaircraft missile fired from helicopter pods or from hand-held gripstock launchers. Wt: 30 kg per case of 2, Price: \$1200 per case (R/R).

Large Caliber Rounds

20mm HE: Wt:.5 kg ea, 50 kgs per 100 round belt, Price: \$450 per case (S/R).

20mm AP: Wt:.5 kg ea, 50 kgs per 100 round belt, Price: \$450 per belt (S/R).

25mm Oerlikon HE: Wt:100 kg per case of 33, belted, Price: \$500 per case (R/R).

25mm Oerlikon AP: Wt:100 kg per case of 33, belted, Price: \$500 per case (R/R).

30mm Bofors HE: Wt:100 kg per case of 33, belted, Price: \$520 per case (R/R).

30mm Bofors AP: Wt:100 kg per case of 33, belted, Price:

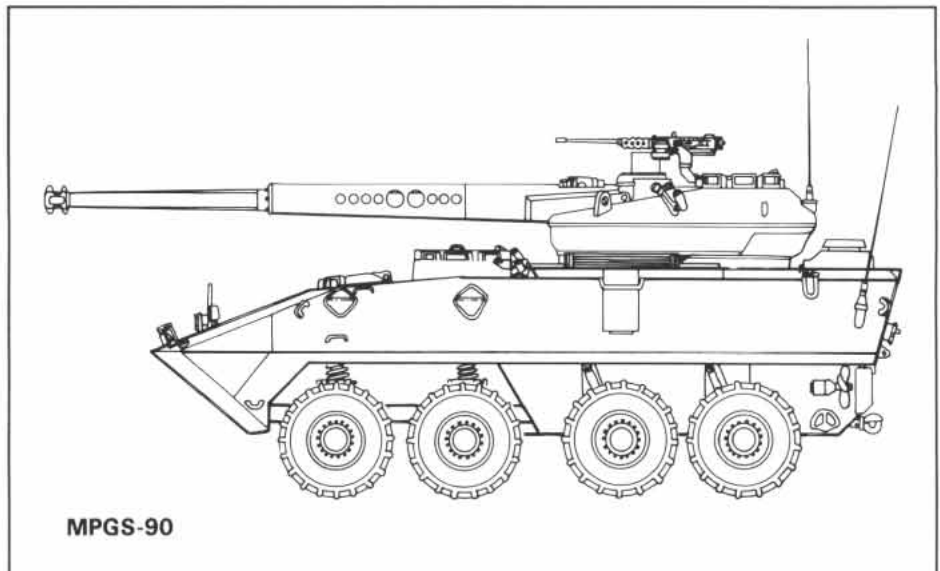

\$520 per case (R/R).

90mm APDS: An armor piercing discarding sabot round. Wt:31 kg, Price: \$500 (R/R).

90mm HE: Wt:31 kg, Price: \$500 (R/R).

90mm HEAT: Wt:31 kg, Price: \$500 (R/R).

90mm APERS: A "beehive" type antipersonnel round, which scatters hundreds of flechettes over the burst radius. Wt:31 kg, Price: \$500 (R/R).

90mm WP: Wt:31 kg, Price: \$500 (R/R).

165mm HEP-T: A "squash-head" round, designed for destroying concrete bunkers. Wt:19 kg, Price: \$2000 (R/R).

Howitzer Rounds

105mm how HE: Wt:30 kg, Price: \$600 (R/R).

105mm how ICM: Wt:30 kg, Price: \$600 (R/R).

105mm how WP: Wt:30 kg, Price: \$600 (R/R).

203mm how HE: Wt:96 kg, Price: \$900 (S/R).

203mm how ICM: Wt:96 kg, Price: \$900 (S/R).

203mm how ILLUM: Wt:96 kg, Price: \$900 (S/R).

203mm how CHEM: Wt:96 kg, Price: \$900 (S/R).

203mm how Powder Charge: Wt:22 kg, Price: \$600 (S/R).

Other Equipment

Blazer Reactive Armor: These are special explosive charges fastened to an AFV for additional armor. Reactive armor units explode when hit by any round larger than 35mm. The explosion is directed outwards, and interferes with HEAT type warheads on rockets, shells, missiles, and grenades. This provides an additional 400 units of armor for the location covered. Reactive armor has no effect on kinetic energy penetrators.

Reactive armor units may be applied to the glacis, turret front, turret sides and turret back faces of any AFV which has the appropriate attachment lugs. Installing lugs requires welding equipment and one man/hour per lug. Replacing a unit takes 10 minutes.

A unit covers 10% of an armor face, and is destroyed when activated. The number of units hit times 10 is the percent chance of hitting a part of the face unprotected by reactive armor. If for instance a tank had lost three units from one face, there would be a 30% chance of each subsequent hit striking an unprotected spot. Price: \$5000 (R/R) Wt: 10 kg.

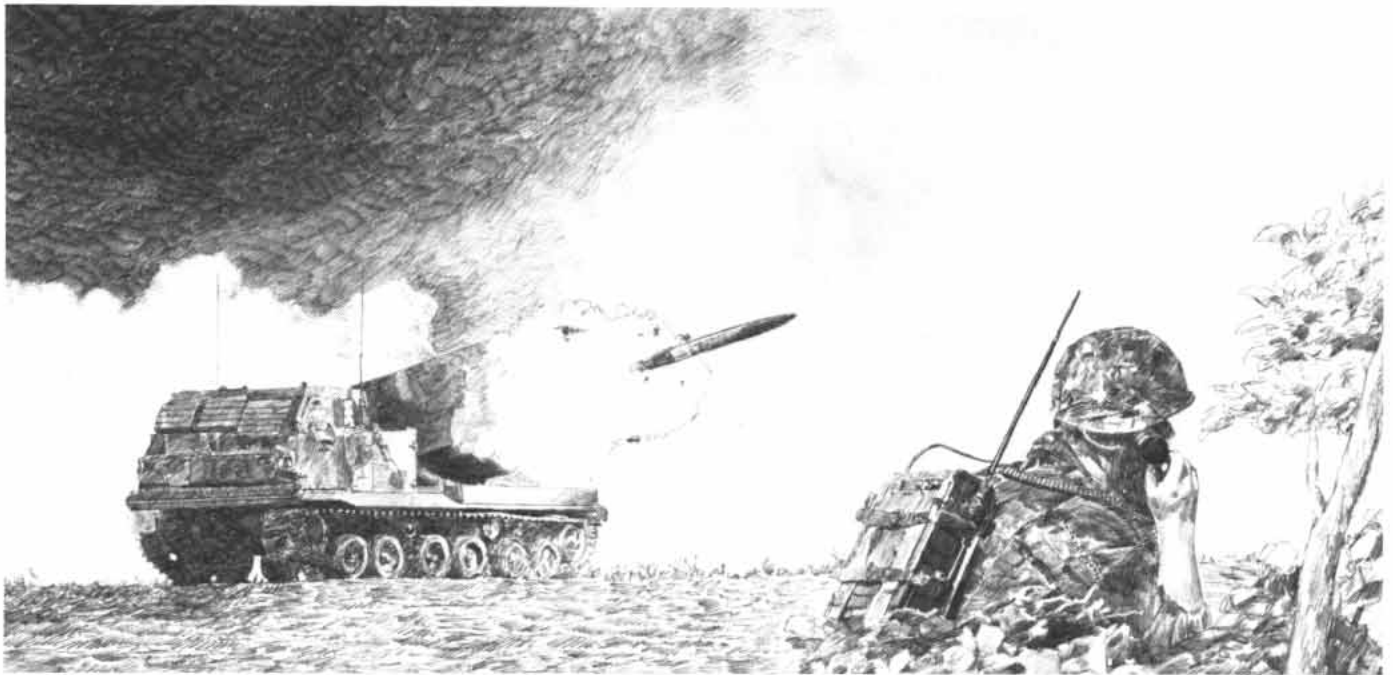

Additions to the Fire Charts

Rocket Launchers

Type	Rnd	Rng	Dam	Arm	KDR	Burst	IDR
160mm Rkt HE		350	× 35C	× 8	25	50	25000
ROF: 2	ICM	—	× 10C	× 10	40	60	25000
Mag: 12	CHEM	350	× 2C	× 10	—	25	25000
227mm Rkt HE		400	× 40C	× 10	30	60	30000
ROF: 2	ICM	—	× 12C	× 10	60	100	30000
Mag: 12	ILLUM	—	—	× 10	—	2200	30000
	CHEM	—	× 2C	× 10	—	30	30000

Reloading 6 rounds takes 12 turns for both

Antiarmor Missiles

Type	ROF	Mag	Rng	Dam	Arm	KDR	Burst
Hellfire	1	4*	4000	× 45C	—	10	15
ADATS	1	4*	8000	× 50C	—	10	15

* one shot takes 2 rounds to reload

Antiaircraft Missiles

Type	ROF	Mag	Rng	Dam	Arm	KDR	Burst
Chapparral	1	4*	18000	× 20C	× 10	2.5	15
Roland II	1	2**	18000	× 20C	× 10	2.5	15
ADATS	1	4**	8000	× 50C	—	10	15
Stinger	1	1/2	6000	× 10C	× 10	—	5

* 1 missile takes 4 rounds to reload.

** 2 missiles take 2 rounds to reload.

Large Caliber Guns

Type	Rnd	Rng	Dam	Arm	KDR	Burst
20mm Vul	AP	1200	× 3	—	—	—
ROF: 5	HE	1200	× 4C	× 10	2.5	2.5
Mag: 100						

Large Caliber Guns (continued)

Type	Rnd	Rng	Dam	Arm	KDR	Burst
25mm Oerl	HE	250	× 5C	× 10	2.5	5
ROF: 5	AP	250	× 5	—	—	—
30mm Bof	HE	250	× 5C	× 10	2.5	5
ROF: 4	AP	250	× 5	—	—	5
90mm gun	HE	250	× 20C	× 10	5	10
ROF: 1	APDS	300	× 25	—	—	—
Mag: 1	APERS	250	× 10C	× 10	10	15
	HEAT	250	× 20C	—	5	10
	WP	250	× 10C	× 10	—	15
165mm gun						
ROF: 1	HEP-T	125	× 40C	—	20	30
Mag: (2)						

Howitzers

Type	Rnd	Rng	Dam	Arm	KDR	Burst	IDR
105mm	HE	250	× 20C	× 10	5	10	9000
ROF: 1	APERS	250	× 20C	× 10	10	15	9000
Mag: (2)							
	HEAT	250	× 20C	—	5	10	9000
	ILLUM	—	—	—	—	1000	9000
	WP	—	× 20C	× 10	—	15	9000
203mm	HE	—	× 40C	× 5	40	60	20000
ROF: 1	ICM	—	× 30C	× 10	50	80	20000
Mag: (3)							
	ILLUM	—	—	—	—	2000	20000
	CHEM	—	× 2C	× 10	—	25	20000
	WP	—	× 15C	× 10	—	30	20000

Additions to the Vehicle Damage Location Lists

Unarmored Cargo

HMMWV (all variants)

Per unarmored cargo listing, referee's charts.

TRUCK, CARGO, 5/4 TON,

Per unarmored cargo listing, referee's charts.

FAV (Fast Attack Vehicle)

Per unarmored cargo listing, referee's charts (if kevlar shields are deployed, passengers and cargo are considered to have an armor value of 10).

M648 10-TON CARGO CARRIER

Per unarmored cargo listing, referee's charts.

M548 6-TON CARGO CARRIER

Per unarmored cargo listing, referee's charts.

M48 CHAPARRAL

Per unarmored cargo listing, referee's charts. Any S (stores) hits become W (weapon) hits.

M993 MLRS

Per unarmored cargo listing, referee's charts. Any S (stores) hits become W (weapon) hits.

M948 LARS

Per unarmored cargo listing, referee's charts. Any S (stores) hits become W (weapon) hits.

Armored Personnel Carriers

M113A3 & M113A3 ACCV

Per standard listing.

M115A1 ACCV

R: LH(30), G(30), HB(10) E,F,P
L: LH(30), G(30), HB(10) D,R,C
R: TF(30), TB(30) X,N,W
C: TF(30), TB(30) X,W,N,G
L: TF(30), TB(30) N,W,G
TS(30) G,N,W,X
F: HS(10) D,E,F
C: HS(10) G,S,P
B: HS(10) S,P
FD(10) D,E,F
TD(15) X,W,N,G
BD(10) P,S

M2A3 BRADLEY II

R: LH(30), G(55), HB(15) E,F,A,P
L: LH(30), G(55), HB(15) D,R,S,P
R: TF(40), TB(40) M,W,C
C: TF(40), TB(40) W
L: TF(40), TB(40) M,C,W
TS(40) M,W,G,C
F: HS(15) D,E,F
C: HS(15) S,C,G,A
B: HS(15) S,P
FD(10) D,E,F
TD(10) C,G,X,M,W,N
BD(10) P,S

AAVP9

R: LH(35), G(35), HB(30) E,F,P,S
L: LH(35), G(35), HB(30) E,F,D,C,P,S
L: TF, TB miss
R: TF(30), TB(30) W,G
C: TF, TB miss
TS(30) W,G
F: HS(40) C,D,E,F,A
C: HS(40) A,P,S
B: HS(40) P,S
FD(15) E,F,D
TD(15) G,W
BD(15) P,S

Light Combat Vehicles

M750 AC (COMMANDO V-350)

R: LH(20), G(30), HB(20) E,F,A,P
L: LH(20), G(30), HB(20) D,R,S,P
R: TF(30), TB (20) G
C: TF(30), TB (20) W
L: TF(30), TB (20) W,G,N
TS(20) W,G
F: HS(25) D,C,A
C: HS(25) P,C,F
B: HS(25) E,P,S
FD(10) D,C,F
TD(10) G,W,N
BD(10) E,P,S

PEACEKEEPER ARMORED CAR

R: LH(20), G(25), HB(20) E,F,D
L: LH(20), G(25), HB(20) E,F,C
R, C, & L: TF(10), TB(0) W,G
TS(0) G,W
F: HS(20) D,E,R
C: HS(20) S,A,P
B: HS(20) P,S
FD(5) D,P,F
TD(0) G,W
BD(5) P,S

M577A1 CP

R: LH(30), G(30), HB(10) E,F,R
L: LH(30), G(30), HB(10) D,R,P
R, L & C: TF(30), TB(10) R,P
F: HS(15) D,E,F
C: HS(15) S,R,P
B: HS(15) S,P
FD(10) D,E,F
TD(10) R,S,P
BD(10) S,P

M18 MORTAR CARRIER

R: LH(30), G(55), HB(15) E,F,A,P
L: LH(30), G(55), HB(15) D,R,W,C
R, C, & L: TF, TB, TS miss
F: HS(15) D,E,F
C: HS(15) P,W,A
B: HS(15) P,W,S
FD(10) D,E,F
TD(0) W,A,P
BD(0) W,P

M106 MORTAR CARRIER

R: LH(30), G(30), HB(10) E,F,C
L: LH(30), G(30), HB(10) D,R,P
R & L TF, TB Miss
C: TF, TB Miss
F: HS(10) D,E,F
C: HS(10) P,W,A
B: HS(10) P,W,S
FD(10) D,E,F
TD(0) W,A,P
BD(0) W,P

Engineer Vehicles

M728 CEV

R: LH(220), G(220), HB(160) D,R,G,E,F
L: LH(220), G(220), HB(160) D,L,S,E,F
R: TF(240), TB (120) G,C,A
C: TF(240), TB (120) X,W*,N,A
L: TF(240), TB (120) L,A
TS(120) L,C,G,W*,A,X
F: HS(80) D,R
C: HS(80) L,G,S
B: HS(80) E,F
FD(25) D,R
TD(25) X,W*,C,G,L,N,A
BD(25) F,E,A

* There is a 50% chance a weapon hit will be in the turret-mounted crane rather than the 165mm gun. The crane's armor multiplier is $\times 50$.

M1 AVLB

R: LH(200), G(1000), HB(80) D,R,G,E,F
L: LH(200), G(1000), HB(80) D,L,S,E,F
R, C & L TF, TB, TS *
F: HS(80) D,R
C: HS(80) L,G,S
B: HS(80) E,F
FD(50) *(D,R)
TD(10) *(C,S)
BD(50) *(F,E,A)

• Any turret or deck hits are taken in the bridge, which has a damage multiplier of $\times 50$. If the bridge has been deployed, turret hits count as misses, deck hits use the parenthetical ratings.

M60 AVLB

R: LH(220), G(220), HB(160) D,R,G,E,F
L: LH(220), G(220), HB(160) D,L,S,E,F
R, C, & L: TF, TB, TS *
F: HS(80) D,R
C: HS(80) L,G,S
B: HS(80) E,F
FD(25) *(D,R)
TD(25) *(C,S)
BD(25) *(F,E)

• Any turret or deck hits are taken in the bridge, which has a damage multiplier of $\times 50$. If the bridge has been deployed, turret hits count as misses, deck hits use the parenthetical ratings.

Main Battle Tanks

M60A4

R: LH(220), G(220), HB(160) D,R,G,E,F
L: LH(220), G(220), HB(160) D,L,S,E,F
R: TF(240), TB (120) G,C,A
C: TF(240), TB (120) X,W,N,A
L: TF(240), TB (120) L,A
TS(120) L,C,G,W,A,X
F: HS(80) D,R
C: HS(80) L,G,S
B: HS(80) E,F
FD(25) D,R
TD(25) X,W,C,G,L,N,S,A
BD(25) F,E,A

CADILLAC GAGE STINGRAY

R: LH(180), G(240), HB(140) D,R,G,E,F
L: LH(180), G(240), HB(140) D,L,S,E,F
R: TF(200), TB (140) G,C,A
C: TF(200), TB (140) X,W,N,A
L: TF(200), TB (140) L,A
TS(100) L,C,G,W,A,X
F: HS(100) D,R
C: HS(100) L,G,S
B: HS(100) E,F
FD(60) D,R
TD(60) X,W,C,G,L,N,S,A
BD(60) F,E,A

Self-Propelled Artillery

M691 DIANA

R: LH(200), G(1000), HB(80) D,R,C,E,F
L: LH(200), G(1000), HB(80) D,S,E,F
R: TF(20), TB (10) G,A
C: TF(20), TB (10) W,N,A
L: TF(20), TB (10) L,A
TS(10) L,G,W,A
F: HS(80) D,C,R
C: HS(80) L,G,S
B: HS(80) E,F
FD(50) D,R

TD(10) W,G,L,N,A
 BD(50) F,E,A1

M17 LAVAA

R: LH(20), G(40), HB(15) C,S,P,E,F
 L: LH(20), G(40), HB(15) D,R,S,G,E,F
 R & L: TF(20), TB(20) N,M
 C: TF(30), TB(30) N,M
 TS(30) M
 F: HS(20) D,R,C
 C: HS(20) G,P,S
 B: HS(20) F,E
 FD: (10) D,R,C
 TD: (10) N,M
 BD: (10) F,E,S

MPGS-90

R: LH(20), G(40), HB(15) C,S,P,E,F
 L: LH(20), G(40), HB(15) D,R,S,P,E,F
 R: TF(35), TB (25) X,W,L,R
 C: TF(35), TB (25) X,W,N,G
 L: TF(35), TB (25) N,G,W
 TS(25) W,N,G
 F: HS(20) D,R,C
 C: HS(20) P,G,S
 B: HS(20) F,E
 FD(15) D,R,C
 TD(15) X,W,N,G
 BD(15) P,S,F,E

LAV-PIVAD

R: LH(20), G(40), HB(15) C,S,P,E,F
 L: LH(20), G(40), HB(15) D,R,S,P,E,F
 R: TF(30), TB (20) X,W,L,R
 C: TF(30), TB (20) X,W,N,G
 L: TF(30), TB (20) N,G,W
 TS(20) W,G,N
 F: HS(20) D,R,C
 C: HS(20) P,G,S
 B: HS(20) F,E
 FD(15) D,R,C
 TD(15) X,W,N,G
 BD(15) P,S,F,E

M901 ITV

R: LH(30), G(30), HB(10) E,F,P
 L: LH(30), G(30), HB(10) D,R,C
 R & L TF, TB miss
 C: TF(10), TB (10) N,M
 TS(30) M,N
 F: HS(10) D,R,C
 C: HS(10) P,S
 B: HS(10) L,A
 FD(10) D,R,C
 TD(0) M
 BD (10) L,A

M990 ADA

R: LH(40), G(60), HB(10) D,G,A,R,E,F
 L: LH(40), G(60), HB(10) D,C,A,S,E,F
 R: TF(80), TB (10) N,W,L
 C: TF(80), TB (10) W,N,A,L
 L: TF(80), TB (10) W,N,L,A
 TS(10) C,R,G,W,A,L
 F: HS(10) D,R
 C: HS(10) C,G,A,S
 B: HS(10) E,F
 FD(10) D,R
 TD(10) W,N,A,L,C,G
 BD(10) F,E,S

M741A6 PIVAD

R: LH(30), G(30), HB(10) E,F,P
 L: LH(30), G(30), HB(10) D,R,P
 R: TF(20), TB(10) N,W,G
 C: TF(20), TB(10) W,N,A,L
 L: TF(20), TB(10) C,W,L,G

TS(10) C,W,G
 F: HS(10) D,E,F
 C: HS(10) G,S,P
 B: HS(10) S,P
 FD(10) D,E,F
 TD(10) W,G
 BD (10) P,S

M757 BLAZER

R: LH(30), G(55), HB(15) E,F,A,P
 L: LH(30), G(55), HB(15) D,R,S,P
 R: TF(40), TB (40) X,C
 C: TF(40), TB (40) W,M
 L: TF(40), TB (40) M,X,G,W,N
 TS(40) M,W,G,C
 F: HS(15) D,E,F
 C: HS(15) S,C,G,A
 B: HS(15) S,P
 FD(10) D,E,F
 TD(10) W,M,G
 BD(10) P,S

M920 M2 HELLFIRE AT VEHICLE

R: LH(30), G(55), HB(15) E,F,A,P
 L: LH(30), G(55), HB(15) D,R,S,P
 R & L TF, TB miss
 C: TF(0), TB (0) N,M
 TS(0) M
 F: HS(15) D,E,F
 C: HS(15) S,C,G,A
 B: HS(15) S,P
 FD(10) D,E,F
 TD(0) M,N
 BD(10) P,S

M110A2 SP

R: LH(30), G(50), HB(15) E,F
 L: LH(30), G(50), HB(15) D,R
 R: TF(0), TB(0) W,G,L
 C: TF(0), TB(0) G,W,L
 L: TF(0), TB(0) G,C,L,A,W
 TS(0) G,L,C,A,W
 F: HS(15) D,R,F,E
 C: HS(15) E,F
 B: HS(15) F,E
 FD(15) E,F
 TD(0) P,W,A
 BD(15) E,F

M917 ADATS (AIR DEFENSE ANTITANK SYSTEM)

R: LH(40), G(60), HB(10) D,G,A,R,E,F
 L: LH(40), G(60), HB(10) D,C,A,S,E,F
 R: TF(0), TB(0) M
 L: TF(0), TB(0) M
 C: TF(0), TB (0) N,M
 TS(10) M
 F: HS(10) D,R
 C: HS(10) C,G,A,S
 B: HS(10) E,F
 FD(10) D,R
 TD(10) M,N
 BD(10) F,E,S

M975A3 ROLAND II

R: LH(30), G(50), HB(15) E,F,P,A
 L: LH(30), G(50), HB(15) D,R,C,A,L
 R: TF(10), TB(10) P,N
 C: TF(10), TB(10) M,N
 L: TF(10), TB(10) M
 TS(20) M,N,P
 F: HS(15) D,R,F,E
 C: HS(15) C,M,N,P
 B: HS(15) L,A
 FD(15) D,R,F,E
 TD(15) N,M,P
 BD(15) L,A



The Color Plate Notes

A1: M1 of 1-803 Armor (Washington National Guard), 36th Infantry Division (Mechanized); Poland, summer 1997.

A vehicle from Alpha company of the battalion, this tank features the fairly complex autumn camouflage pattern which was usually applied with fewer colors and less care. The tank's tactical marking ("A-19") is painted in yellow on the turret front and the tank's name ("Terminator") is on the gun tube forward of the bore evacuator. When viewing this and subsequent plates, the reader should remember that, by regulation, the vehicle tactical markings (such as "A-19" in this case) followed no Army-wide pattern. Certain conventions were fairly universally used, such as reservation of the number 6 for the unit commander. Presumably, this vehicle is from Alpha Companies first platoon. However, there were only four vehicles to a platoon, so it should not be assumed that this was the ninth vehicle in the platoon, or even the company.

The photograph from which this plate was taken was made approximately a week after the battle of Sulechów (6/3/97), the battalion's first engagement of the war. Tank A-19 ("Terminator") apparently performed quite well as it has two red "kill" stars painted on the turret front and an additional half star indicating a shared kill. Very few vehicles continued to carry prominent identifying numerals long after arrival in Germany, and the fact that "Terminator" still carries hers (and is in almost factory-fresh condition) further confirms the time of the photograph.

A2: M1A1 of 2nd Armored Division; Germany, summer 1998.

As with many vehicles in Germany, the lack of external unit markings makes it difficult to identify the unit to which this tank belonged with assurance. However, it is almost certainly from either the 1-67 or 3-67 Armor. Both of these battalions were equipped with M1A1s and both adopted the curious habit of marking kills with red barrel rings instead of stars. One source holds that this was an in-joke in the 67th Armored Regiment

and was adopted due to the M1A1 being armed with the German Rheinmetal 120mm gun. (The Bundeswehr universally used barrel rings to denote kills.)

The tank's name ("The Whole Can") is painted on the turret front and is the only identifying marking on the vehicle. The two small white crosses on the gun tube immediately forward of the mantlet are memory marks, recording the deaths in combat of two crew members. Usually these memory marks listed the crewman's name and rank immediately below the cross and the date of death below that. Presumably the same format was followed here, but the notations under the crosses are illegible in the original photograph.

Two items of interest can be seen in the tank's skirt armor. First, the last skirt plate has been removed. This was extremely common on M1s of all marks for two reasons. With the rear skirt plate on, dirt and debris tended to accumulate around the idler, causing occasional mechanical difficulties. Second, it was necessary to gain access to the rear suspension area fairly often for maintenance purposes. Permanent removal of the rear skirt plate solved the first problem and made the second much easier.

The second item of interest is the second skirt plate from the front. This plate was apparently damaged in combat and has fairly recently been replaced by a part from another tank, the work being done by an ordnance workshop unit. Note that the camouflage paint on that panel, although similar in overall appearance, does not match the surrounding plates. Chalked (or painted) in yellow on the plate is the depot unit number ("221-1"), the mechanic's check of the work ("OK") and the date of replacement ("7-98", or July of 1998).

A3: M1A2, 3-70 Armor, 5th Infantry Division (Mechanized); Germany, fall, 1997(?).

A remarkably high cross-country speed coupled with the bizarre appearance of its raised remote turret earned the M1A2 the nickname "Giraffe." One soldier's explanation of this nickname was that "It looks like something out of a zoo." It is difficult to place this particular example of the tank due to

its lack of external markings. Fortunately, the serial number has not been painted over and this vehicle (1702601) was assigned to the 3-70 Armor, a component battalion of the 5th Division. The vehicle has been in Germany long enough to lose most of its external unit markings (for security purposes) but still retains the vehicle name ("Lisa Gaye") on the turret and the driver's name ("Steve #1") on the superstructure. The significance of "#1" is unclear.

A4: *M691 Diana, 4-5 Air Defense Artillery, 1st Cavalry Division; Poland, spring 1997.*

The cancellation of the M988 DIVAD air defense gun in the mid-80's, and relegation of the existing models to National Guard service, caused the adoption of a number of experimental and stop-gap solutions to the self-propelled air defense gun requirement. This is a good color study of the M691 Diana air defense vehicle, one of the many different self-propelled air defense guns in use by the U.S. Army in the 1990's. The vehicle itself consists of twin Oerlikon 25mm KBB automatic cannons mounted in a fully rotating turret on an M1 chassis. The vehicle serial number is still visible on the rear hull superstructure and allows identification of the unit to which it was assigned. The vehicle name ("Super Duster") is painted on the turret side below the national star.

B1: *M60A4, 1-127 Armor, 42nd Infantry Division (New York National Guard); Jugoslavia, spring, 1999.*

In 1987 the U.S. Army adopted the M60A4 as type standard and began upgrading all M60 A1 and A3 versions to the A4 standard. In the case of the existing M60A3 fleet, this amounted only to adding armored skirts to the sides and attachment lugs to the turret and glacis for reactive armor plates. This color plate provides a good study of the M60A4's distinctive, if somewhat ugly, appearance. The insert to the right shows the appearance of the turret with the reactive armor plates removed.

By 1997 most units earmarked for Europe had been equipped with various marks of M1 Abrams tanks. However, the M60A4 remained in the inventory, particularly in the divisional tank battalions of non-mechanized infantry divisions (as is the case with this particular example). A number of M60A4's also eventually made their way to Germany and were used to replace combat losses in several units originally equipped with M1's.

The tank in question clearly shows its serial number (2187132) on the central storage box above the side skirts and its name ("The Demon") on the rear superstructure.

B2: *Cadillac Gage Stingray of 4-34 Armor, 8th Division (Mechanized); Poland, spring of 2000.*

Following the retreat from central Poland in the autumn of 1997, the 8th Division was withdrawn from the lines to refit and reorganize. Armored vehicle losses had been heavy and all remaining tanks in the division were assigned to 1-68 and 3-77 Armor, while 2-68 and 5-77 Armor were disbanded to provide personnel replacement for the other two battalions. The remaining tank battalion in the division, 4-34 Armor, was left without any vehicles of its own, but a convoy of heavy equipment had recently arrived in Europe (one of the last to do so) and included in the cargo was a consignment of Cadillac Gage Stingrays which

were used to reequip the battalion.

The Stingray was a private venture tank designed and built by Cadillac Gage for the export market. The Stingrays in question were originally manufactured for the Pakistani Army and were awaiting shipment when the war broke out. At that time all shipments of war materiel were frozen and in early 1997 the Stingrays were requisitioned. (The vehicle in this plate still retains markings on its rear superstructure showing that it was requisitioned in February of 1997 by Field Materials Headquarters Company 12.)

The flamboyantly painted vehicle in this plate belonged to Captain Wilbur Stentz of Mountain Home, Idaho, and served as the company command tank for Bravo Company, 4-34 Armor during the spring offensive into Poland and, later, Latvia. The vehicle driver was SSgt Kent Venters and his name (along with his wife's name, Marsha) is painted on the left forward superstructure. The tank's name is "Pink Cadillac" while "The Spirit of Mountain Home Idaho" is the commander's marking on the turret side. By the spring of 2000 the tank had 13 tank kills (red kill stars on the turret front) and had also shot down four aircraft, three SU-25's and one larger aircraft. The caption provided with the photograph by the U.S. Army identifies the fourth aircraft as an SU-17, but the silhouette in the actual photograph is unmistakably that of a USAF F-111.

Immediately above the kill stars on the turret front is a single memory mark, indicating a crewmember killed in combat, followed by two mushroom clouds, indicating the tank has twice survived on a nuclear battlefield. Barely legible below the clouds are the dates of the battles: 12-98 and 3-99 (December of 1998 and March of 1999).

The serial number on the rear superstructure (12 21917) is the Pakistani Army serial number which has been retained on the vehicle with the addition of "U.S. Army Ordnance" below it. The tank retains its original Pakistani color camouflage scheme with only two alterations: the Pakistani Army markings on the back half of the turret side have been rather crudely painted over with black paint and a black national star has been stenciled onto the turret side.

In addition to the Stingrays sent to Germany, a small number were retained in depots in the United States and in 1999 were turned over to the 49th Armored Division in Oklahoma to replace tank losses.

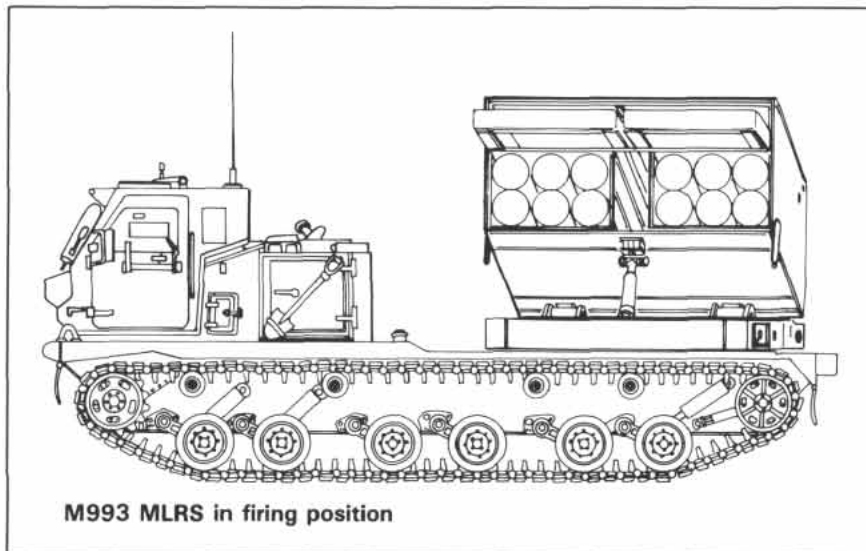

M993 MLRS in firing position



B3: LAV-75 of 2-60 Infantry, 9th Infantry Division (Motorized); Iran, spring of 1998.

The LAV-75 was originally acquired in response to a requirement for a light tank capable of rapid air deployment with light divisions. It was used to equip the newly-organized divisional tank battalions of the Army's light divisions as well as the assault gun battalions of 9th Motorized Division. At about the same time, the Army issued a requirement for a light air-droppable tank to replace the M551 Sheridan, then equipping the 3-73 Armor (Airborne) of the 82nd Airborne Division. The M551 had never been satisfactory in that role and had been retained primarily as a face-saving gesture. As it happened, the LAV-75 proved admirably suited to the 3-73rd's mission and, with few alterations, was adopted.

The LAV-75 shown is from Charlie Company of the 2-60 Infantry (Assault Gun), 9th Motorized Division. The vehicle, in this case, can be identified from its serial number (11B76621A) on the superstructure side. The vehicle name ("The Final Solution") is painted on the gun tube housing, and the driver has painted his hometown ("Chicago") on the side of his cupola.

B4: M17 LAVAA (Light Armored Vehicle, Anti Armor) of 11th Marine Artillery Regiment, 1st Marine Division; Iran, autumn of 1999.

The First Battalion, 11th Marines became a holding unit for a variety of specialist units of the 1st Marine Division in Iran. As combat casualties increased and replacements dwindled, the division began instituting centralized control of its more powerful fire assets. Waco battery of 1-11 Marines became the holding unit for the division's remaining M17 anti-armor vehicles. The M17 was a straight-forward LAV-25 conversion accomplished by substituting the TOW II Launch system for the 25mm chain-gun turret.

The vehicle shown retains clear unit markings on the rear hull side identifying it as the sixth vehicle of the battery. The vehicle name ("Striker II") is just forward of this. Note the "Sling" stencils by the lifting rings at the front and back of the vehicle and the USMC serial number at the very upper front of the vehicle side.

C1: M2 Bradley infantry fighting vehicle of Headquarters Com-

pany, 2nd Brigade, 24th Infantry Division (Mechanized); Iran, autumn, 1997.

The M2 Bradley was the standard infantry fighting vehicle in service with U.S. mechanized infantry during the war. This plate shows a vehicle in quite good condition and painted in the mixed sand and green camouflage pattern adopted by many units in the Persian Gulf. Many vehicle markings are visible, most of which would have disappeared after another season of combat. The black numeral on the turret indicates that the vehicle is vehicle eight in its platoon. Still visible on the side skirt are several peacetime safety stencils (which were often ignored in combat situations). The top read "Do not ride on vehicle" while the one below it reads "Stay clear of turret." Towards the rear of the vehicle is a yellow radiation symbol and the notation "Rad Def", indicating that this vehicle is a radiological recon vehicle of the brigade's NBC (Nuclear, Biological, Chemical) warfare defense platoon. As such, it was undoubtedly fitted with a variety of radiological and chemical sensors internally. Also still visible is the "Lift/Tow" stencil by the front lift ring. Standard markings are rounded out by the black national star on the turret and the vehicle serial number (11022).

Crew personal markings consist of the vehicle name, "Tally Ho", on the turret side and two personal markings of the track commander. "Illinois" is the track commander's home state and "Joyce of Midlothian" is the track commander's wife or girlfriend.

Despite the natty appearance of the vehicle overall, it has apparently been in combat recently, as it shows fragmentation damage to the armored track skirt and the stowage box on the rear of the turret.

C2: LAV-25 of E Troop, 44th Cavalry Squadron (Composite), 44th Armored Division; Bavaria, autumn 1999.

The LAV-25 was originally adopted as a light armored personnel carrier and fire support vehicle for use by the Marines and the 9th Infantry Division (Motorized), but the versatility of the vehicle soon caused its adoption to a wide variety of tasks. In many of the non-divisional National Guard cavalry units it was issued as a replacement for the M113 armored personnel carrier, as shown in this plate.

When the 44th Armored Division was formed from three separate National Guard brigades, the brigade cavalry troops were combined to form a composite divisional cavalry squadron, designated the 44th. A Troop, 230th Cavalry (Tennessee NG) became A Troop, 44th Cavalry; B Troop, 713th Cavalry (South Carolina NG) became B Troop, 44th Cavalry; and E Troop, 31st Cavalry (Alabama National Guard) became E Troop, 44th Cavalry.

The vehicle shown is heavily weathered, but still shows its lift stencils by the front and rear lift rings. The vehicle serial number is probably still present as well, but is obscured by the canvas bags hung from the side. The vehicle's name ("Ivan Eater") is barely legible immediately ahead of the driver's hatch. The turret bears two commander's marks, "Death in Spades" at the turret front and "Rusty Butt" toward the center. Rusty Butt was probably the commander's nickname. Below it is painted "Alabama", the crew's home state. A Confederate battle flag is hung from the radio antenna.

C3: LAV-PIVAD of 3-62 Air Defense Artillery, 10th Infantry Division (Mountain); British Columbia, summer of 1997.

When the DIVAD program was cancelled, work on PIVAD

(Product Improved Vulcan Air Defense) was accelerated and by the 1990's was the most common gun system in use by U.S. air defense artillery units. In response to a requirement for a light weight mobile air defense gun system for use with light divisions, PIVAD was mounted on a LAV-25 chassis and issued to the air defense battalions of the 62nd Air Defense Artillery Regiment, the component battalions of which provided air defense assets for the regular army light divisions. (1-62 ADA with 25th Division, 2-62 ADA with 7th Division, 3-62 ADA with 10th Division and 4-62 ADA with 6th Division.)

The vehicle shown is in good shape and has relatively few markings. The serial number (11B7260) is clearly visible just to the rear of the turret ring on the vehicle side. The "lift" stencils by the front and back lift rings are barely visible in white. Aside from a small black national recognition star on the hull side, the only other markings are the vehicle name, "Friendly Fire", and a cartoon on the hull side.

C4: M113A3 armored personnel carrier of 2-136 Infantry (Minnesota National Guard), 36th Infantry Division (Mechanized); Germany, autumn of 1997.

M2 Bradley production was never sufficient to provide all National Guard mechanized troops with infantry fighting vehicles, and as a result many units continued to use the M113 armored personnel carrier. The vehicle shown is vehicle 34 (perhaps the fourth vehicle of the third platoon of a company) of the 2-136 Mechanized Infantry, and is unusual in being free of any personal markings by the crew. The "Lift Here" stencils by the front and back lift rings are still visible as is the serial number (12A88071). The vehicle's side skirts have been removed (fairly common, as the rubber center panels tended to deteriorate quickly in combat and replacements were not available) and the .50 caliber machinegun on the commander's cupola has been replaced by a Mark 19 grenade launcher (also very common).

D1: HMMWV squad carrier of 9th Infantry Division (Motorized); Iran, autumn of 1998.

Most of the plates on this page show tactical vehicles of the 9th Division in the Persian Gulf theater. This particular version of the HMMWV was the standard utility truck of the division, used to carry both light cargo and personnel. On this version the doors, cab roof and rear roof have been removed and the vehicle was used as an ammo carrier for a mortar squad. The serial number, which was normally painted on the side of the engine hood, was obscured in the original photograph by the leg of a rifleman riding on the hood. Note that the roll bar behind the seat is clearly visible in this view.

D2: HMMWV squad carrier of 3-47 Infantry, 9th Infantry Division (Motorized); Iran, autumn of 1998.

Five of the nine maneuver battalions of 9th Infantry Division were organized as light motorized infantry, each battalion consisting of two light companies, one heavy company and one antiarmor company. The two light companies were carried in HMMWV squad carriers as shown in this plate.

This vehicle is very typical of the type used as personnel carriers. The ring mount is fitted with a .50 caliber machinegun,

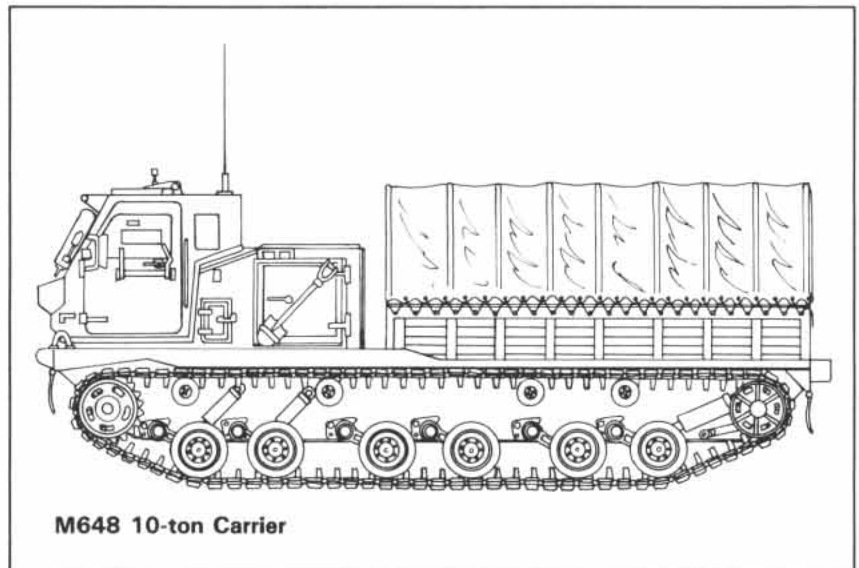

although Mark 19 grenade launchers were more common. The crew's personal possessions are stored on the rear of the cab. On this vehicle the serial number (12C77618) is on the rear cab side and above it is the vehicle name ("Lone Wolf") and a black wolf silhouette. The only other vehicle marking is a stencilled star on the door.

D3: HMMWV ambulance of the 2046th Mobile Surgical Hospital; Germany, summer of 1997.

The HMMWV proved to be useful in a variety of roles and this plate shows the ambulance. In addition to a slightly longer cargo bed, the HMMWV ambulance included internal racks for two stretchers and a life support system. The tactical markings indicate that it is pool vehicle number 2, but no serial number is visible. Pool vehicles were generally provided by units served by or located near the MSH unit. Therefore, this vehicle may originally have been issued to almost any U.S. unit of any service branch.

D4: HMMWV TOW carrier of 2-2 Infantry, 9th Infantry Division (Motorized); Iran, autumn of 1998.

Each of the antiarmor companies of the five light motorized battalions of the 9th Division included three antiarmor platoons with six TOW II launchers each. In one platoon these were LAVAA vehicles, while in the other two platoons they were mounted on standard HMMWV squad carriers. The normal mounting position of the TOW II launcher was above the cab which enabled it to be fired in any direction. The vehicle pictured here, however, has had the launcher mounted on the rear deck. While this served to reduce the overall vehicle silhouette, it also restricted the field of fire to the vehicle's sides and required exposing the cab to fire.

The tactical marking below the black national star indicates that this is vehicle number 29 in the company (probably a vehicle of the 2nd platoon). The serial number (22B7167) is visible on the hood, as is the vehicle name ("Road Runner") painted on the door immediately below the window.

D5: HMMWV fire support vehicle of 2-23 Infantry, 9th Infantry Division (Motorized); Iran, autumn of 1998.

The antiarmor company of each light motorized battalion included, in addition to its three platoons of TOW carriers, one platoon of six fire support vehicles. The fire support vehicle was

a standard HMMWV modified to support a power-driven 25mm chaingun remote turret. The gun was aimed by means of a downlinked television monitor located on the gunner's console (to the right of the driver).

This vehicle clearly shows its serial number (62B77617) on the hood, a small black national star on the rear fender, and the vehicle name ("The Exterminator") on the rear side panel.

D6: *5/4-ton utility truck of 183rd Tactical Fighter Group (Reinforced); Al Qatif, Saudi Arabia, summer of 1998.*

This is an excellent view of a light tactical vehicle as used by USAF airfield security police around the world, its role clearly marked by a number of unique features. Mounted on top of the roll bar behind the cab is a siren and flashing red light. On top of the cab there is, in addition to the familiar whip antenna, a VHF blade antenna for ground-to-air communication. In addition to the serial number on the door (1772703), the tactical markings on the side of the truck bed identify this as the fifth vehicle from the 183rd Tactical Fighter Group (Reinforced) security police.

D7: *Fast Attack Vehicle of the 9th Infantry Division (Motorized); Iran, autumn of 1998.*

Two battalions of the 9th Division (2-1 and 3-1 Infantry) were equipped as fast attack battalions. In addition, the battalion scout platoons of the division's five motorized battalions were mounted in fast attack vehicles. Given the very small exposed surface areas of the FAV, identifiable vehicles are extremely rare and it is impossible to place this vehicle with any certainty. However, the absence of a weapons mount means that it was probably a command or liaison vehicle in the headquarters company of 2-1 or 3-1 Infantry. FAVs were usually armed with Mark 19 grenade launchers, .50 caliber machineguns, or TOW II launchers.

D8: *Fast Attack Vehicle of 1-9 Infantry, 6th Infantry Division (Light); Germany, winter of 1999.*

In the late 1980's it was decided to outfit one infantry battalion in each light division as a light motorized battalion. In 6th Division, 1-9 filled this slot. The battalion was organized along the same lines as the light motorized battalions of 9th Division. The vehicle shown is almost certainly from the scout platoon of the battalion and is included to show the position of the weapon mount.

Although intended primarily as a scout vehicle, it was recognized fairly early that the FAV would often be involved in combat situations and would provide the crew with virtually no protection from small arms fire or shell fragments. As a result, all FAVs were provided with Kevlar side and top sheets that attached to the roll bar framework. These provided moderately good protection from shell fragments and small caliber small arms fire, but have been deleted from the plates to provide a better view of the vehicle interior. The Kevlar sheets were usually rolled up so as not to interfere with crew visibility.

E1: *M750 (Commando V-350) of 278th Armored Cavalry Regiment; Germany, spring 1998*

The 278th Armored Cavalry Regiment (Tennessee National Guard) lost most of its heavy equipment to Soviet naval commerce raiders while deploying to Europe in the winter of 1996-97. Upon arrival, all vehicles were pooled to equip the 2nd squadron, which was then committed to action. 1st and 3rd



squadrons were made mobile by requisitioning civilian transport, but were provided a number of light armored vehicles as well. While a few of these were exotic conversions of civilian trucks to armored cars, the majority were light armored vehicles used for airfield defense by the U.S. Air Force. By the end of 1997, further losses had forced reorganization of the regiment as a single composite squadron. The picture from which this plate was made was taken in April of 1998 after the reorganization was complete.

The vehicle shown externally is a fairly typical V-350 as outfitted for airfield defense. It mounts a Cadillac Gage machinegun turret and vehicles like this could be found anywhere in the globe where the USAF manned bases. It was painted green overall with no camouflage scheme, and was heavily weathered by the time this photograph was taken. In this case, however, the vehicle was extensively modified internally as it served as the command post vehicle for the composite squadron. The vehicle name ("Lady Jane") is painted prominently on the side of the vehicle hull and marks it as Lt. Colonel Dwight Bergstrom's command vehicle. (Jane Bergstrom Davis was the colonel's daughter.) "Black Water Alligator" on the turret is the vehicle commander's marking, in this case belonging to MSgt Wade Pruitt of Valdosta, Georgia. The vehicle driver is from Denver, Colorado as evidenced by the red "Denver" by the driver's hatch.

Commando V-350's were also used by U.S. Army military police units (and were designated M750 in Army service) for base security and convoy escort duty, and when MP units were committed as actual combat troops the V-350 performed adequately as an armored personnel carrier and light armored fighting vehicle. The pintel mount M2HB .50 caliber heavy machinegun was standard issue, although it was often replaced in the field by a Mark 19 grenade launcher.

E2: *Peacekeeper armored car of 278th Armored Cavalry Regiment; Germany, spring 1998.*

Another vehicle from the 278th ACR contemporaneous with that shown in Plate E1, the Peacekeeper was also most commonly used by USAF security police for airfield security. This particular peacekeeper has apparently been recently repainted which accounts for it having acquired a camouflage pattern and

for the less weathered look of the vehicle compared to "Lady Jane". Note the searchlight mounted on the machinegun gunshield. This was a common feature on airfield security vehicles and has been retained by this crew.

In addition to airfield defense, a number of Peacekeepers were also acquired by the Department of Energy in the early 1980's for nuclear reactor security. A number of Peacekeepers of both USAF and DOE origin were used in 1999 to replace vehicle losses in the 49th Armored Division in Oklahoma.

E3: *M113A3 armored cavalry combat vehicle, 1-803 Armor (Washington National Guard); Poland, summer 1997.*

The 1-803 Armor formed part of the 81st Mechanized Brigade (Washington National Guard) which deployed to Germany as an organic brigade of the 36th Infantry Division (Mechanized). In common with many national guard units, the 1-803 had not yet re-equipped with the M1/M2 family of vehicles and thus was primarily equipped with M60A4 main battle tanks. The vehicle shown, however, is from the battalion's scout platoon, which was equipped with M113A3 ACCV's.

The ACCV shown has few markings, but can be identified by its serial number (4417627B). The vehicle name ("Polish Sportster") is on the rear side. Note also the "Lift" stencils at the front and back and arrows indicating the vehicle's lift rings.

E4: *M115A1 armored cavalry combat vehicle of 163rd Armored Cavalry Regiment (Montana National Guard); Korea, 1998.*

In the mid-1990's the armed forces entered a number of emergency production orders for a variety of LAV-25 variants (some of which are illustrated elsewhere). One effect of this shifting of priority to LAV variants was that for a period of time there were a number of surplus 25mm chaingun turrets available. As M3 Deevers production had never been sufficient to provide the National Guard with modern cavalry fighting vehicles, a number of M113 chassis were fitted with surplus 25mm chaingun turrets and issued to the Montana National Guard as "Surrogate Cavalry Fighting Vehicle XM115". In February of 1996 the type was standardized, with a few modifications, as the M115A1 Armored Cavalry Combat Vehicle and steps were taken to begin mass production. The outbreak of war overtook these plans but conversion of existing M113A3 ACCV's to the M115A1 standard continued through 1998. A number of M115A1 vehicles were shipped to Europe and used to replace vehicle losses, and others were employed by mechanized units in the United States. The 163rd ACR, however, was the only unit entirely equipped with the vehicle.

The vehicle shown in the plate was commanded by MSgt Roland G. Mills of Iowa City, Iowa, and the turret bears both his wife's name, Vickie, and his hometown on the side forward of the side vision block. (How MSgt Mills came to be in a regiment of Montana national guardsmen is not certain.) Aft of the vision block are kill marks indicating two BRDM scout cars, one BMP, one aircraft, and eight soft-skinned troop transport vehicles destroyed. The vehicle driver was Sgt William A. Jefferson and his fiance's name, Buela, is painted immediately under the vehicle serial number (17A076325).

F1: *M901 antiarmor vehicle of 256th Mechanized Brigade (Louisiana National Guard), 5th Infantry Division (Mechanized); Poland, summer of 2000.*

Although Hellfire launchers mounted on M2 chassis were used



to equip the antiarmor companies of regular army mechanized battalions by the mid-90's, the M901 ITV (Improved TOW Vehicle) was still used throughout the National Guard, even in round-out brigades such as the 256th.

This ITV is the fourth vehicle in D company, as indicated by the large black tactical marking on the rear vehicle side. The vehicle serial number (12AD77851) is visible below the driver's vision blocks as are the "Lift Here" stencils beneath the front and rear lift rings. The gunner has painted his name ("Andy V.") on the launch tube and the track commander has added his hometown ("New Orleans") on the reloading hatch. The vehicle's name ("Jaynie") is prominent between the national star and tactical marking.

F2: *M2A3 infantry fighting vehicle of 2nd Armored Division; Germany, spring of 1997.*

While the M2 Bradley was a satisfactory infantry fighting vehicle, in the early 1990's the need was felt to increase its antiarmor firepower. The result was the M2A3. The chassis of the vehicle was unchanged. The unmanned remote turret was smaller than the manned turret of the M2 and in place of the twin TOW II launcher on the left side of the turret, one Hellfire missile launcher was installed on each side. The weapon system was now fired from the gunner's station inside the vehicle and was aimed by means of a downlinked television monitor.

The example shown here is from the 2nd Armored division, but is identifiable as such only because of the marking of other vehicles in the same photograph. For some reason, Army censors have airbrushed out all markings on this vehicle in the photograph.

F3: *M18 mortar carrier of 11th Marine Artillery Regiment, 1st Marine Division; Iran, summer 2000.*

The M18 was the mortar carrier variant of the M2 Bradley IFV. The modification consisted of deletion of the turret and extensive internal changes to allow emplacement of the M121 120mm mortar. The interesting thing about this particular vehicle is that the M18 was never issued to the USMC, and thus this appears to have been pirated from an Army unit.

Despite its possibly shady origin, the vehicle bears a very proper set of markings. The small tactical markings on the fender

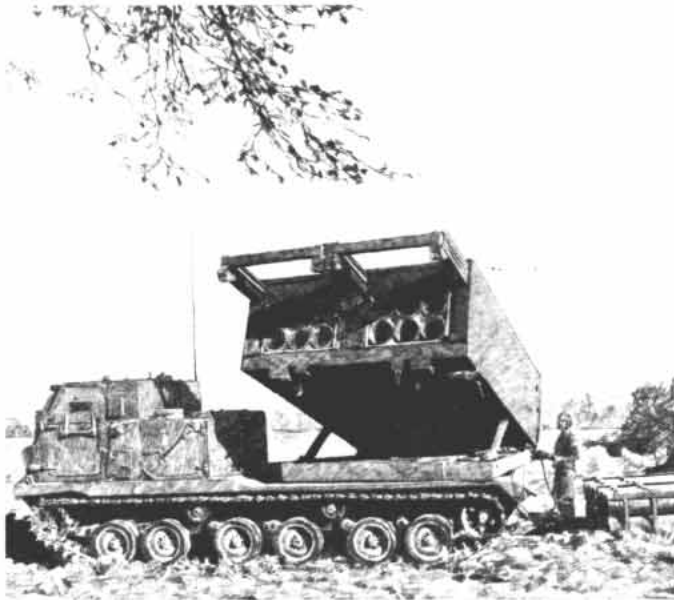

skirt identify the unit as Tango Battery, First Battalion, 11th Marine Artillery Regiment, 1st Marine Division. The large 5 to the rear indicates that this is the fifth vehicle of the battery. On the superstructure side is the serial number ("USMC 171209", apparently fabricated, as this serial number was officially assigned to a refueling truck of the 49th Air Group). "Cecilia Burns" is painted below the driver's vision blocks, apparently the wife or girlfriend of the driver. Note that the firing ports have been plated over. Note also the aiming stakes stored on the side of the superstructure between the two passenger vision blocks.

F4: M106 mortar carrier of 3-5 Marines, 1st Marine Division; Iran, summer of 2000.

As part of Third Army's summer offensive into eastern Iran, elements of 1st Marine Division conducted amphibious assaults along the Persian Gulf coast. This plate was taken from a photograph showing heavy equipment shortly after offloading on a beach near Chah Bahar, Iran. As Third Battalion, Fifth Marines formed the MAU (Marine Amphibious Unit) which captured Chah Bahar, this vehicle is almost certainly from that battalion. However, censors have airbrushed out most of the vehicle's tactical markings for security reasons. The only remaining tactical marking is the large yellow 2 indicating the vehicle is the second track in the battery. Also visible are the lift stencils by the front and rear lift rings and the USMC serial number (12761).

In the original photograph a beachmaster is standing next to the vehicle and obscures its name. The first three letters, however, were "Pog..." and the name was probably a variant on "Pogey-bait". The 5th Marines were often referred to as "The Pogey-bait 5th Marines", a term of mild derision in which the regiment came to take a sort of perverse pride. The name (pogey-bait was a slang term for candy) apparently originated before or during the Korean War (versions differ) when the 5th by accident received a shipload of candy and other comestibles instead of supplies of a more military nature, giving rise to the following rhyme:

"We're the Pogey-bait Fifth Marines.
We can't keep our rifles clean.
Don't give us a BAR;
Just give us a candy bar."

This rhyme was seldom recited directly to a member of the regiment more than once.

Note that the vehicle in this picture carries the massive baseplate and bipod for its 4.2" mortar slung on the vehicle side. The vehicle's mortar could be dismounted and fired from a firing pit using these, although it was more commonly fired from the carrier. One unusual feature of this vehicle is that it still has rubber track skirts (although they show considerable wear). Very few M113-type vehicles still retained these by 2000.

G1: M577A1 command post vehicle of 3-112 Armor, 49th Armored Division (Texas National Guard); Oklahoma, summer 1999.

Under the U.S. Army's regimental system, each state which had any armored units had a state armored regiment to which all such units belonged. In many cases this resulted in one-battalion regiments (and in the case of armored cavalry sometimes a one-troop regiment), but as the entire 49th Armored Division was a Texas National Guard Unit, the 112th Armored Regiment boasted a total of six battalions.

The vehicle shown in this plate is a heavily weathered command post vehicle from the headquarters company of the 3-112 Armor. The serial number (14A02234) allows identification of the unit, but no tactical markings are visible. At full strength the headquarters company would have eight such vehicles. (One carrying the S-2 section, one with the S-3 section, one with the S-4 section, one with the commo platoon, two carrying the headquarters section of the battalion's mortar platoon, and two carrying the battalion aid station section.) The lack of red cross markings makes it probable that the vehicle was from one of the staff sections. However, by 1999 personnel and vehicle losses resulted in most battalion staffs operating on a very reduced and streamlined establishment. In some battalions, a single M577A1 carried the "battalion staff", a team of a half-dozen or so specialists who coped with problems that the book said called for many times their number.

G2: M990 of 1-4 Air Defense Artillery, 9th Infantry Division (Motorized); Iran, spring of 1998.

In keeping with its tradition of using the weirdest vehicle possible for the task at hand, the 9th Division adopted the M990 as a tracked air defense gun in the late 1980's. Despite its unusual appearance, the M990 was a cheap and effective air defense vehicle. It consisted of two 30mm Bofors cannon (which had originally been tested for use on the DIVAD) mounted on either side of a lightweight turret. In addition to the ammunition feed system, the turret mounted the radar and fire control system developed for the DIVAD (with some slight modifications for enhanced reliability) and was mounted in place of the Aries 75mm autocannon on a standard LAV-75 chassis.

The vehicle shown is gun number one of Charlie Battery, 1-4 ADA, the divisional ADA battalion. The vehicle serial number (182177A6) is painted on the superstructure while the vehicle name ("C'est Le Guerre") is on the gun. On the side of the turret at the rear is a national recognition star so small as to be of no use at all. This is the sort of star a crew paints after having been ordered to paint one somewhere on the vehicle.

G3: M728 combat engineer vehicle of 1-185 Armor (California National Guard), 40th Infantry Division (Mechanized); California, spring of 2000.

The M728 CEV (Combat Engineer Vehicle) was a variant of

the M60 tank. The turret was slightly enlarged to accept the 165mm demolition gun mounted in place of the standard 105mm gun. A winch was fitted to the rear of the turret and a large crane framework was attached to the turret sides toward the front. While travelling, this framework was folded back, but is shown in this plate deployed for lifting a road obstacle.

The normal assignment of CEVs was a section of two vehicles in the headquarters platoon of each line engineer company. This particular vehicle, however, has been pressed into service as a surrogate tank. (By 2000 virtually anything with armor and a gun was being used by armored units in the United States as a tank.) Its serial number (939650) is still visible on the superstructure just below the turret. The vehicle's name ("Dragin' Wagon") is on the turret side just behind the black national recognition star.

G4: *M741A6 PIVAD of 5-62 Air Defense Artillery, The School Brigade; Oklahoma, summer of 1999.*

The 5th Battalion, 62nd Air Defense Artillery was a regular army ADA battalion stationed at Fort Bliss, Texas, and assigned to the Air Defense Center's School Brigade. It provided hands-on training for the M741A6 PIVAD (Product Improved Vulcan Air Defense) system that still filled the gap created by the cancellation of the Sgt York DIVAD system in 1985. When hostilities with Mexico began in 1998, the School Brigade at Fort Bliss was activated as a troop unit, complete with infantry battalions out of the local basic training barracks, artillery from the New Mexico National Guard, and the 1-124 Cavalry Squadron (Texas National Guard) from Waco. The Air Defense Center naturally provided an abundance of air defense units, including a Patriot missile battalion, a battalion of composite air defense weapons, and the 5-62 ADA. Batteries and platoons of the battalion were active in a number of rear guard actions during the retreat of the School Brigade from central Texas to Oklahoma. In 1998, the School Brigade was attached to the 49th Armored Division.

The vehicle shown is a good study of the M741A6 PIVAD. In common with most M113-type vehicles at this stage of the war, its track skirts have been removed. The large bulky panels on the vehicle side are styrofoam flotation panels covered by sheet metal. The weight of the gun system was such that these panels were necessary for the vehicle to retain its amphibious capability.

The vehicle name ("The 4 Horsemen") is painted on the turret side and the serial number (2281108) is still faintly visible on the superstructure behind the turret and just above the flotation panel. The quick stencil version outline recognition star is painted on the side of the flotation panel.

H1: *M109A2 self-propelled howitzer of 3-41 Field Artillery, 3rd Infantry Division; Korea, autumn 1997.*

The M109A2 was the workhorse of U.S. field artillery throughout the war. This view provides a good detailed look at the vehicle, and shows off the lengthened gun tube (the distinguishing feature of the A1 version) to good effect. This vehicle was Battery C's third gun, as indicated by the yellow "3" on the bore evacuator. The vehicle name ("Long Arm Of The Law") is painted on the gun tube immediately behind the bore evacuator and the section chief has painted "Britt" on the turret side just forward of his hatch, apparently the name of a wife or girlfriend.

Note that the gun tube is carried in the travel position in the

upright travel lock.

H2: *M110A2 self-propelled gun of 2-32 Field Artillery, 41st Artillery Brigade; Germany, December 1996.*

The basic corps general support weapon for U.S. forces was the M110A2 self-propelled 8" gun. The gun shown in this plate belonged to 41st Artillery Brigade, which supported the U.S. V Corps in its initial offensive into eastern Germany in 1996. It is relatively devoid of markings, showing only a vehicle name ("Eve Of Destruction") on the gun tube and faded serial number (J70031) on the superstructure. Note that the gun's massive recoil spades are folded up in the travel position.

H3: *M993 Multiple Launch Rocket System of Battery A, 13th Field Artillery Regiment, 24th Infantry Division (Mechanized); Iran, autumn 1998.*

In the early 1980's the general support artillery battalion of each U.S. division, which had consisted of a mix of 8" howitzers and multiple launch rocket systems, was reduced to a single MLRS battery. These became separate batteries not associated with any particular battalion and serving directly under the divisional artillery commander.

This particular MLRS, painted in one of the several desert camouflage patterns used during the war, was driven by TSgt Rebecca Coolidge of Heber Springs, AR, and bears the driver's marking "Rebecca's Ride" on the lower driver's door. The vehicle name, "Pandora's Box", is painted prominently on the launch tube housing.

H4: *M948 Light Artillery Rocket System (LARS) of Battery E, 11th Field Artillery Regiment, 6th Infantry Division (Light); Finland, July, 1997.*

The LARS filled the same role in light divisions as the MLRS filled in the heavy divisions: a separate general support rocket battery at division level. In line with the higher priority given deployability in light division, the LARS was a considerably smaller vehicle and fired 160mm rockets instead of the 227mm giants of the MLRS. It was, nonetheless, a powerful system that provided the backbone of the division's indirect firepower.

This M948 was driven by SSgt Gerry Drumwald and the door marking consists of the name of the sergeant and his wife ("Brenda"). They lived in Titusville, Florida, which is painted on the launch tube housing just below the vehicle name ("Snake In The Grass"). The unit can be identified from the still-legible serial number (2B16841) just below the national recognition star.

Vehicle Modeling Tips

Vehicles are very important to the world of *Twilight: 2000*. Generally, there aren't a lot of them at one place at any given time, but there is a great deal of variety. In most game situations you are unlikely to encounter (or be part of) a full company of one type of tanks. It is more likely you will run into a group of motorized infantry (or horsed cavalry) supported by a few armored vehicles. The infantry would probably be mounted in a variety of military and civilian vehicles. The armored vehicles might include one tank and one or two armored personnel carriers. Many of the vehicles would show considerable wear and tear, and would probably have a great deal of cargo and personal possessions carried on the outside. This makes the world of *Twilight: 2000* a modeler's and gamer's paradise for two reasons. First, you don't have to make up lots of vehicles of the same types. Second, each vehicle is unique and you can have a lot of fun customizing it.

SCALE

When GDW negotiated a miniatures license with Grenadier Models for *Twilight: 2000* miniatures, we made one absolute demand: the miniatures *had* to be HO (or 20mm) scale. A lot of gamers have asked why we went with this scale instead of the more common 25mm scale. A glance at the pictures in this section should give you the answer. There is a very wide variety of vehicles and scenery already available in HO scale. The Grenadier Models figures, being in HO scale, have two big advantages over 25mm scale figures. First, you get more of them for your money. A pack of HO scale figures probably costs about the same as a typical pack of 25's, but will usually have two or three more figures in it. Second, HO scale figures can be used with HO scale buildings, terrain and (most importantly) vehicles. The 25's just look too large compared to most HO vehicles. For this reason, HO scale metal figures (or 20's) have been quite popular in England for some time, particularly such lines as Platoon 20 and Firefight 20. Given the excellent detail that modern 20mm figures achieve, it is quite likely that within a few years all popular modern gaming figures will be in this scale.

AVAILABILITY OF MODELS

The most common and easily available models in this scale are the well-known Roco line (also known as Minitanks). These are available in most hobby game stores and are carried by a number of distributors as well. Roco vehicles are manufactured in Austria and imported so sometimes particular vehicles will not be in stock. However, many hobby store owners are willing to order specific vehicles from distributors. A second supplier is the Spanish firm Eko, who makes vehicles in the same scale as the Roco line. These are not usually displayed in stores, but again many hobby dealers are willing to place special orders for them. Finally, Roskopf makes a line of vehicles slightly smaller than the Roco/Eko lines, but includes many useful vehicles that can be used as is or as the basis for conversions. (By the way, the Roco Opel firetruck makes a very good medium

still truck with no work other than a paint job.)

In metal, several companies in the United Kingdom make vehicles in the 20mm scale. Check out Platoon 20, Firefight 20 and Ahketon in particular. Usually you can find an address for these firms, or a direct mail dealer, in issues of *Military Modeling* or *Miniature Wargaming* (inquire at your hobby shop for these magazines).

CONVERSIONS

Despite the variety of vehicles available, there are many which simply aren't made but are used in *Twilight: 2000*. A large number of these can be made with some fairly simple conversion work. The accompanying photographs illustrate several of these.

LAV-25: A quick and dirty LAV-25 can be obtained by taking the turret of the Roco German *Luchs* (Lynx) armored car and placing it on the body of the Roco German *Fuchs* Transport Panzer 1 (TPZ1) armored personnel carrier. This will give you a fair visual representation of the LAV-25. With a little additional work you can improve it considerably. First, get some thin sheet styrene (available at most hobby shops). Use it to plate over the doors and windows on the front of the vehicle and give the front the more angular look of the actual LAV-25. Next, obtain another set of wheels from another kit. By shifting the three axles of the *Fuchs* and adding a fourth you end up with a very good game replica of the LAV-25. This is the conversion shown in the photographs.

BTR-70: After you have done the LAV-25 conversion, you will have the body of the Roco *Luchs* armored car, but no turret.



Get the Eko PT-76 Soviet amphibious tank model and remove the turret. Cut the gun barrel off so that only about 5mm is left. carve out a larger turret ring in the top of the *Luchs* body and put the PT-76 turret in. The result is a good impression of the eight-wheeled BTR-70.

BMP: For this conversion I used the PT-76 chassis and the turret from a Roskopf French six-wheel armored car. Cut a round piece of sheet styrene to fill in the turret hole of the PT-76 and then mount the small turret from the armored car in the middle of the chassis. I used the missile from a Roco UH-1 helicopter kit and glued it to the top of the gun mount. This produced a vehicle that looks like a BMP-A. A piece of brass or plastic tubing (also from the hobby shop) about a half inch long on a plastic pedestal would be more appropriate for a BMP-B or C.

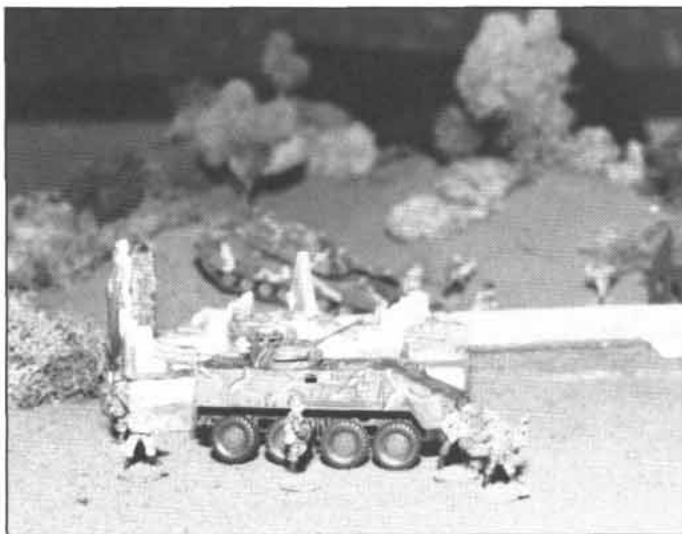

M113 ACAV: The standard Roco M113 is fine for a personnel carrier. The ACAV variant is mostly recognizable by its gun shield. If you keep a parts box, dig through it and find a small angled gun shield (the one in the photo is from a light antiaircraft gun). (If you don't keep a parts box, start one—just put all your leftover parts and scraps into a shoebox or something.) Otherwise a gunshield can be made out of sheet styrene. Add a spare machinegun (Roco manufactures a machinegun packet containing several types) and you're finished.

General Suggestions: The above examples are not meant to be a complete catalog of the conversion possibilities. These are very simple conversions that occurred to me just by looking at a number of vehicles and letting my imagination go. Ask yourself what parts of one vehicle remind you of another. Use your imagination and remember that they don't have to be exact replicas. We're not starting an armor museum, just playing a game. In a game it is usually enough to suggest the image of a vehicle. If you get the general size and shape right, the viewer's imagination will take over and fill in the details.

A good example is the BTR-70 conversion above. If you look closely it has a number of features that are clearly different from a BTR-70. The turret is too large, the chassis front and back are not shaped the same as a BTR, and there are numerous details that are totally different. However, there are about three gross characteristics of a BTR-70 that make it easily recognizable: It has eight wheels, it has a roughly symmetrical lozenge-shaped hull, and it has a conical machinegun turret. The conversion above captures those gross characteristics well enough that people forget the fine details when looking at it. When this vehicle was displayed at GenCon in 1985 along with some *Twilight: 2000* miniatures from Grenadier, numerous people stopped to ask "Where did you get the BTR-70?" They did not ask "Is this supposed to be a BTR-70?" or "What's this supposed to be?"

PAINTING

All vehicles should be painted for one very good reason. Plastic

kits are molded in polystyrene that comes out of the mold smooth and shiny. This glossy surface reflects much more light than a real vehicle to scale would and gives it an unrealistic, toy-like appearance. Just a simple coat of flat paint, even if you do nothing else to the vehicle, will improve its looks tremendously. Flat paints are available in most hobby shops. For a basic vehicle covering, I recommend getting paint in spray cans (unless you have an air brush). A variety of greens are available and should do for most vehicles.

If more detail is desired or perhaps a special color not available in spray paints, I strongly recommend that you use a latex or acrylic paint. These are available from a variety of suppliers and your hobby dealer will help you here. The advantages of acrylics are: 1) They use water as a thinner and for clean-up (this is a big plus from your wallet's viewpoint, and your work area will smell a lot better, too); 2) They are easy to mix and thin; 3) When doing washes (see the section on weathering below) the washes tend to dry with more of a flat (non-gloss) appearance. Many times even flat enamels take on a gloss when you make a wash with enamel thinner.

CUSTOMIZING

Customizing means making each vehicle unique. This is done by putting boxes, barrels, bundles, bags, extra weapons, camouflage netting, tarps and all sorts of personal possessions on the vehicle. No two crews store this stuff alike and so every vehicle becomes very individualistic. The two M113's in the photographs illustrate this well. Customizing is very important, and adds a great deal of realism to your models. It is fairly easy



and also makes it easier to do conversions. Why? Because you can hide your mistakes and cover up unwanted details with all of the gear on the top of the vehicle.

There are a lot of sources of gear for customizing. Roco makes a number of sets of customizing parts and loading goods. Many model railroad companies have a wide assortment of small HO scale items used in railroad dioramas that are quite good for this. (I once saw a customized vehicle piled up with crates, bags, tents and other gear and on top of it all was a kitchen sink—courtesy of an HO scale railroad layout.)

Another source of customizing parts are your Grenadier Models *Twilight: 2000* miniatures. The heavy weapon sets have tripod-mounted weapons (Particularly the U.S. Mark 19 grenade launcher) that can be used to replace machineguns. The Soviet

AT4 launcher is very similar to the launch tube on the BMP-B and C and could be used as part of a conversion. Glueing a figure in the open hatch of a vehicle is also an excellent way of both improving the looks of the vehicle and "establishing the scale." Establishing the scale is a means of reinforcing the fact that the vehicle and infantry figures with it are indeed the same scale and belong together. A figure in a tank hatch, or a passenger in the open rear compartment of an M113, can do wonders here. A figure can also give you something more to anchor the gun to and make the weapon less likely to break off in use.

WEATHERING

Combat vehicles get dirty. When they drive through woods the paint gets scraped off and then the bare metal rusts. They get mud on them and then get dusty over that. Refuelling usually gets a little sloppy and fuel puddles around the gas tank caps, gathering more grime. No one has yet invented an engine that doesn't leak oil somewhere, sometime. Engine exhaust, especially from diesels, is very dirty. Areas around engine grates get greasy and oily from

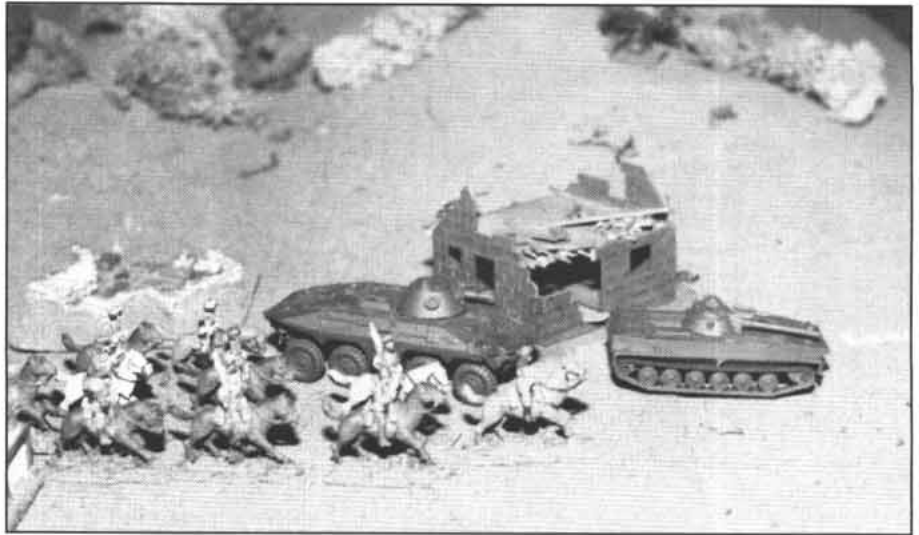

maintenance, and that attracts dirt as well. People are always banging the hatches and doors as they enter and leave the vehicle, chipping paint off. Steps, handles, and latches get the paint worn off them by hundreds of feet and hands. Get the picture?

Weathering is actually the easiest part of doing a model and adds the most to its final appearance. I am not going to give you a lengthy treatise on weathering for diorama work. There are good books available on that, for one thing (which you may want to look at anyway...they have lots of good pointers). For another, many of you probably aren't interested in investing that much time in the model anyway. Don't be intimidated by lengthy discourses on all the different steps and techniques involved. Here are a few simple pointers for weathering that will give you good looking gaming vehicles.

The Black Wash: A wash is very simple and once you get the feel of it you'll be able to do it in the lid of your paint jar. For now, use a paper cup or some similar small container. Put about one good brush-full of black acrylic paint in the bottom. Mix in

a very small amount of water, about the smallest you can manage. This will probably give you about five or six times as much water as paint. Mix this up so that you have black water, not thin black paint (add a little more water if you think you need to—you'll learn the right proportions with a little practice). Now cover the whole vehicle with the wash. As you do so, notice that the wash will tend to settle in cracks and crevices, run down the sides of horizontal surfaces in streaks, and puddle in large open areas. Good. That's just what you want. Let the wash dry. (This will take a couple of hours. Experts let the wash dry overnight. I am not an expert.) Don't pick it up during this time...giant fingerprints on the side of a tank are not realistic. When it's done, note how it brings out the detail of the model.

The Brown Wash: Same routine as before, but with a nice earthy red-brown. When this dries, the vehicle will have a nice muddy, dusty look to it. Where the black still shows, it will look like shadows or oily grime.

Dry Brushing: This is optional (all of this actually), but can add a little more to the vehicle. Use a lighter brown than you used for the wash, maybe even a sand or tan. Put some on your brush and then wipe off enough so that the brush is almost completely dry. Now use the brush in scubbing motions all over the vehicle. This will deposit the paint faintly on the raised surfaces and give you a few lighter areas that look like dried mud. The raised detail areas are called highlights and help give the vehicle a more three-dimensional image.